



Alameda Point Transportation Strategy

November 2005



Prepared for:
City of Alameda

Fehr & Peers' San Francisco Office
604 Mission Street, 4th Floor
San Francisco, CA 94105
T: 415-369-0425
F: 415-369-0426

A Transit-Oriented Vision for Alameda Point

The Preliminary Development Concept for Alameda Point is one of sustainable infill development—reuse of previously developed land to create a walkable, transit-oriented community within the heart of the Bay Area. As described in the Preliminary Development Concept, the redeveloped Alameda Point emphasizes mixed-use, multi-modal and sustainable development. The community will be transit and pedestrian friendly and encourage bicycle commuting. By incorporating diverse land uses, the redevelopment of Alameda Point will maximize the number of people who live and work on the island, as well as the number of shopping, recreation, child care, entertainment, etc. opportunities on the island; subsequently, reducing the number of weekday peak period vehicular trips, especially in the Webster and Posey tubes.¹ The street pattern will be an extension of Alameda's grid of walkable, tree-lined streets with connectivity to adjacent neighborhoods and regional transportation that will be significantly improved over current

conditions. Visual and physical access to the waterfront will be optimized and supported by a comprehensive system of pedestrian and bicycle facilities. Significant transit enhancements will benefit all residents of Alameda. These will include a new ferry terminal integrated into the mixed-use node and a high level of surface transit service, achieved through a phased program which begins with shuttles and graduates to bus rapid transit and possibly fixed rail. The Point will have an aggressive transportation demand management (TDM) plan that will include a multitude of programs including a neighborhood electric vehicle program, car-share program, transit subsidies, and parking management.

The document is divided into four sections:

- Section 1: Describes the recommended transportation strategy to compliment and support the Preliminary Development Concept.
- Section 2: Provides a summary of the transit alternatives considered and the findings that provided the basis for the transportation strategy recommended in Section 1.
- Section 3: Describes and quantifies the traffic conditions and roadway improvements that will result from the Preliminary Development Concept and transportation strategies.
- Section 4: Includes a detailed transportation analysis completed in 2003 for 31 intersections.

¹ The Alameda Point land use plan maximizes densities within the limits set by Measure A. The Transportation Strategy is built around these assumptions but if constraints posed by Measure A were removed, even higher levels of walking could be achieved, particularly for trips internal to Alameda Point.



Preliminary Development Concept Illustrative Plan

Source: Roma Desian Group 2005

SECTION I – TRANSPORTATION STRATEGY REPORT

Table of Contents

EXECUTIVE SUMMARY	2
I. INTRODUCTION	5
Total Travel Demand	6
II. TRANSPORTATION STRATEGY FOR ALAMEDA POINT.....	6
Day One Improvements	6
<i>Eco-Pass.....</i>	<i>7</i>
<i>Transit Services and Transit Center.....</i>	<i>7</i>
<i>Expanded AC Transit Bus Service and Shuttle Service</i>	<i>8</i>
<i>Bicycle Facilities.....</i>	<i>11</i>
<i>Carsharing</i>	<i>11</i>
<i>Parking Strategies.....</i>	<i>12</i>
<i>Guaranteed Ride Home</i>	<i>13</i>
<i>Transportation Coordinator</i>	<i>13</i>
Mid-Term Strategies	14
<i>Rapid Bus and Queue Jump Lanes</i>	<i>14</i>
Long-Term Strategies	15
<i>Bus Rapid Transit.....</i>	<i>15</i>
<i>Light Rail Transit/Streetcar.....</i>	<i>16</i>
<i>Group Rapid Transit.....</i>	<i>17</i>

Table of Figures

FIGURE 1: KEY TRANSIT CORRIDORS.....	5
FIGURE 2: EXISTING AC TRANSIT SERVICE.....	8
FIGURE 3: PROPOSED BUS SERVICE	9
FIGURE 4: CARSHARING POD LOCATIONS.....	12

Transportation Strategy Executive Summary

The transportation strategy for Alameda Point borrows elements from some of the best, most progressive programs in the Bay Area and the country to create a unique transportation environment. The strategy, delivered in phases, strives to:

- Make transit use convenient and reliable for residents and tenants from the first day that homes are occupied through full buildout of the project
- Make walking and bicycling attractive and convenient through land use policies and provision of generous non-motorized transportation facilities
- Minimize vehicular trips through land use, transportation, and parking strategies
- Minimize environmental impacts through the use of low or zero emission vehicles.

The strategy has three key goals for Alameda Point residents and tenants:

To have the best transit ridership in the City

According to the 2000 Census, 15.7 percent of current Alameda residents commute to work via transit. This includes AC Transit's transbay bus lines, regular AC Transit service, The Alameda/Oakland Ferry, and BART. The goal of the transportation strategy is to meet and exceed this percentage for residents and employees of Alameda Point. The first step in achieving this is to create an environment attractive to people likely to use transit by providing good transit connections to employment centers and regional transit. This "Day One" component has several parts. First, as a condition of occupancy, all residents and employers will pay fees to fund **new, faster transit connections** to Downtown Oakland, BART, and regional transit. Every month, residents and employees will receive an "**Eco Pass**," funded through the fees, which will allow them unlimited use of AC Transit and/or shuttle, the Ferry, or BART. There will be **enhanced ferry service** to and from Alameda Point, meaning more frequent ferries. The project will contribute towards the construction of **queue-jumping lanes for buses**, which will allow buses to bypass congestion approaching and exiting the Webster and Posey tubes. There will be **strong pedestrian and bicycle connections** to transit, with a focus on a major transit hub at the Seaplane Lagoon and smaller neighborhood transit nodes throughout the development.

To reduce vehicle trips

The goal of the City's *West End Transportation Demand Management (TDM) Program* is to reduce commercial trips by 30 percent and residential trips by 10 percent. The project at Alameda Point embraces these goals. The involuntary pay-in program described above will make riding transit seamless. Other elements include **parking strategies** to make the cost of parking readily-apparent to homeowners and to minimize the amount of non-residential parking provided by allowing uses with different peak parking demand (i.e., office and retail) to share common parking areas (this is frequently called shared parking); **carsharing** pods located throughout neighborhoods to make it easier for residents to own a single car; a **Guaranteed Ride Home** program making employees more comfortable with using transit to Alameda Point; and a **Transportation Coordinator** in charge of marketing the non-automobile travel options, organizing carpools, administering certain programs, and expanding and improving transportation strategies described in this report.

To work towards long-term transit solutions with island-wide benefits

Because congestion at all the Estuary and regional freeways will continue to worsen, whether or not Alameda Point is fully developed, the City will continue to examine long-term transit solutions, including **Bus Rapid Transit (BRT), Light Rail Transit (LRT), and Group Rapid Transit (GRT)**, which connect to Downtown Oakland and cross-island to the Fruitvale BART Station. These corridors connect to major employment centers in San Francisco and Downtown Oakland, which are easily served by transit. Improvements to these corridors provide island-wide benefits. Routes which are continuous (rather than point-to-point) and expandable gained the most public acceptance. Therefore, strategies such as the aerial tramway and the BART extension, were not as desirable. These solutions work in the corridor from the west end of Alameda to Downtown Oakland, but they fail to create island-wide benefits or to serve a wide variety of destinations along the island itself because they are not expandable. Appendix A contains a discussion of the range of options considered.

The recommended alignments and technologies are described in the report that follows. Each requires significant right-of-way and have high costs. For any of them to be successful, the City must develop strong partnerships with stakeholders including the City of Oakland, BART, AC Transit, and Caltrans. These partnerships can be the foundation for successful grant applications and the development of the ultimate solution for the entire island, not just Alameda Point.

The figure on the following page illustrates the various components of the plan which are detailed in this report.

Components of Sustainable Transportation



Land Use Strategies:

- Around 2,000 housing units
- Approximately 3,000,000 square feet of office use
- Roughly 300,000 square feet of retail space
- Adaptive reuse of the hangers to accommodate much of the proposed office and retail development
- A grid street system
- A mix of land uses
- Attention to pedestrian design details
- Higher-density development to facilitate efficient transit and less reliance on automobiles



Transportation Alternatives:

- Faster transit connection to Downtown Oakland and 12th Street BART station
- New, fast and frequent ferry service from Seaplane Lagoon to San Francisco
- Queue-jump lanes to speed Alameda transit in and out of the Estuary tubes



Long-term Island-wide Transit Alternatives

- Bus Rapid Transit
- Light Rail / Streetcar
- Personal Rapid Transit

Alternatives to Driving:

The goal of the Transportation Demand Management Plan is to reduce off-site vehicle trips generated by commercial uses by 30%, and for residential uses by 10% through:

- Transit "EcoPass" program for residents and employees- free transit trips
- Car-Share programs and neighborhood electric vehicle programs
- Integrated bicycle parking and support facilities
- On-site Transportation Coordinator to manage and promote TDM programs and oversee monitoring to determine program effectiveness
- Reducing the supply of parking to take advantage of shared-parking opportunities generated by mixed use development
- Guaranteed ride home program
- Incentives to tenants who use less than their share of the parking supply, work on-site, and for carpool and vanpool users
- Marketing and information programs to discourage driving
- Strategies to make the cost of residential & commercial parking visible to households and commercial tenants, such as separating the cost of parking in lease agreements with tenants



I. Introduction

The transportation strategy developed for Alameda Point contains some of the best ideas culled from national and international examples, including an essential mix of land uses to reduce vehicle trips, transit improvements, and a comprehensive transportation demand management (TDM) strategy. The synergy among all modes at the new multi-modal transit hub creates multiple competitive, viable alternatives to driving, which is essential to the success of Alameda Point, the City at large, its partner across the estuary, Oakland, and local transit agencies (AC Transit and BART). The following figure displays the key transit corridors for both Alameda Point and the rest of the island. These corridors connect to major employment centers in San Francisco and Downtown Oakland, which are well-served by transit. Improvements to these corridors provide island-wide benefits, as one is a cross-island route connecting to the Fruitvale BART station. The type of transit that might eventually be constructed in these corridors is part of an on-going discussion among the City of Alameda, Oakland, BART, and AC Transit. This report recommends a specific set of transit solutions and indicates which transit options are no longer being considered. Section II includes a summary of all of the potential solutions considered for this report.

Figure 1: Key Transit Corridors



Total Travel Demand

The Alameda Point transportation strategy is based upon a mix of employment, housing and services to reduce the need to travel off-site. The City of Alameda currently has a goal to reduce trips from new development west of Grand Avenue by 10 percent for residential uses and 30 percent for commercial uses.¹ The project at Alameda Point will use a combination of improved transit services, Transportation Demand Management (TDM) measures, and land use strategies to move towards this goal. As the City works to finalize the project description, the next step will be to determine the amount of auto traffic which the project generates and to measure its impact on roadway intersections and corridors. The Environmental Impact Report (EIR) will quantify the number of trips generated by the proposed project, evaluate the magnitude of impacts on the roadway system, and propose mitigation measures to reduce the impacts the project creates.

II. Transportation Strategy for Alameda Point

The transportation strategy will be delivered in three phases:

- *“Day One” Improvements* – These are improvements meant to be in place from the first day the project is occupied. They are elements that the project can fund and implement with minimal outside coordination. They include the menu of Transportation Demand Management (TDM) measures described below and improvements to bus and ferry services which will benefit all Alameda residents.
- *Mid-Term Improvements* – These improvements require additional public and/or private funds, and they require that the City gain more widespread approval from key agencies, including the City of Oakland, BART, AC Transit, and Caltrans. They include queue-jumping lanes for buses on the Oakland side of the Estuary, upgrades to the buses that connect to Downtown Oakland and potentially Fruitvale BART.
- *Long-Term Improvements* – These improvements require significant partnerships and outside funding. When the City is ready to take this step, there is a family of transit types that might be appropriate. The City will continue to examine the prospects for long-term transit over the next year.

Day One Improvements

The “Day One” component of the Plan creates an environment attractive to individuals and families who select their homes based on the walkability, bikability, and transit friendliness of a neighborhood. This set of “Day One” improvements is meant to populate Alameda Point with people who may prefer to own fewer vehicles per household, prefer to make trips in modes other than a single-occupant automobile and to create a strong foundation to expand transit and leverage opportunities for partnerships and funding. It is challenging to change people's travel habits retroactively, so the project at Alameda Point will provide transportation and commute options from the day the first home is occupied in order to make transit as attractive as possible, integrated into people's travel patterns as quickly as possible.

¹ Per the City of Alameda's Traffic Capacity Management Procedure, updated annually

Eco-Pass

The Eco-Pass is a transit pass that will be issued to every new resident and employee at Alameda Point. The Eco-Pass will allow each employee and resident at Alameda Point unlimited access to shuttles, buses, and possibly ferry services. The cost of the passes will be raised through an Alameda Point transit assessment district. The intent of the Eco-Pass is three fold: to encourage residents and businesses to use transit by providing them with unlimited access to extensive transit services, to create a financial incentive structure to attract households and businesses that are willing and interested paying higher fees in return for better transit service, and finally to attract household that are interested in relocating to a neighborhood where they will be able to live with fewer personal cars and make fewer automobile trips.

At minimum, the Eco-Pass program at Alameda Point will provide unlimited access to an Alameda Point shuttle system providing regular and frequent service to Webster Street and Downtown Oakland. The City is currently in discussions with AC Transit to expand the Eco-Pass program, so that the Alameda Point Eco-Pass would provide unlimited access to all AC Transit routes. The Alameda Point Eco-Pass might also be expanded to provide access to the Oakland/Alameda Ferry. If the ferry service is transferred to the Water Transit Authority, then additional discussions with the WTA will be necessary to determine if Eco-Pass is viable on WTA run ferries.

Transit Services and Transit Center

The existing transit alternatives in Alameda consist of local AC Transit bus service as well as transbay bus and ferry services.

Central to realizing the goals of the strategy is enabling a strong intermodal transit hub at Alameda Point that provides seamless linkages between local and regional transit services. Strong connections to BART, ferry, and bus services will be integral elements of this facility. The intermodal transit center is part of the Phase I land use plan. It will be located at the Seaplane Lagoon and will include a bicycle station and transit-supportive retail. The bicycle station will include long-term parking, which may be attended, for commuters who ride their bicycles to the transit hub. Other amenities could include bicycle repair, sale, and rental services. The transit-supportive retail could include uses such as a coffee shop, a dry cleaner, a post office, and other stores selling sundries.

The Day One strategy consists of improved surface transit from Alameda Point to Downtown Oakland and the 12th Street BART station, as well as enhanced ferry service and relocation of the existing ferry terminal. These transit improvements, combined with the TDM program described below, will be part of the first phase of development at Alameda Point.

Bus and Shuttle Service

The Alameda Point Transportation Strategy establishes a 15-minute headway goal for bus and shuttle service from Alameda Point to Downtown Oakland and BART to be provided by AC Transit or a privately operated shuttle services funded by the Eco-Pass program.

AC Transit Line 63 currently connects Alameda Point to Downtown Oakland. It also provides cross-island service, operating on 30-minute headways. The following figure illustrates AC Transit's existing service.

Figure 2: Existing AC Transit Service

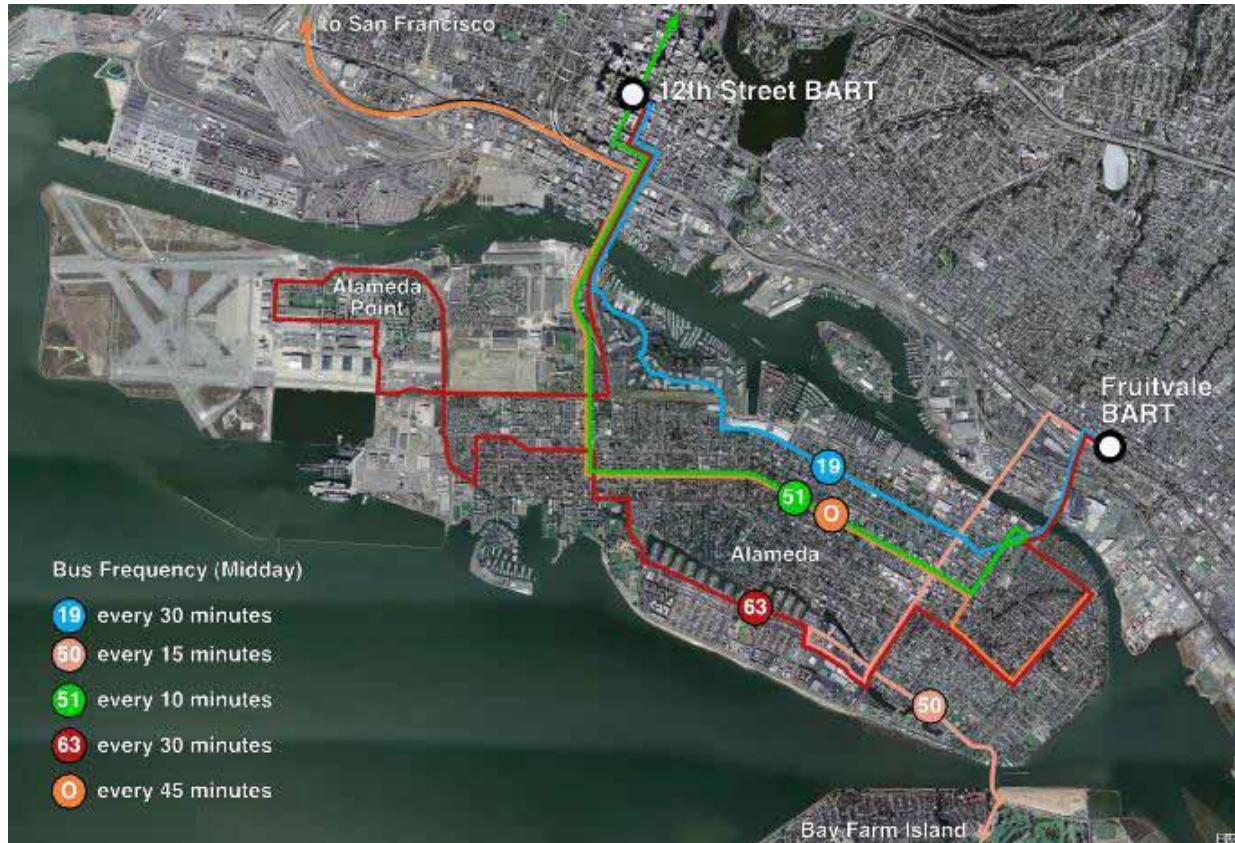

While cross-island service is important, it creates inefficiencies from a transit operations perspective and forces AC Transit to operate on 30-minute headways. This route also creates a long ride for residents picking up the bus in Downtown Oakland with destinations other than the western end of the island.

If AC Transit were to split the current 63 into two lines, one of which would be paid for by the tenants and/or residents of Alameda Point through the Eco-Pass, they could reallocate the resources dedicated to the existing 63 to create a new cross-island service that would operate on shorter headways (i.e. the bus would arrive every 20 minutes instead of every 30 minutes), thus creating a benefit for residents in the east end. West end residents traveling cross-island would board the new Alameda Point service and transfer at Atlantic Avenue/Webster Street. The reconfigured service is illustrated on the following page.

By splitting the line, the west end will get increased AC Transit service. Alternatively, the transit funds raised by the project could provide a supplemental shuttle service running on 15-20 minute headways. This alternative would result in a change in AC Transit's Line 63, and it would complicate service to the rest of the west end, which would not be paying into the new shuttle service.

Figure 3: Proposed Bus Service

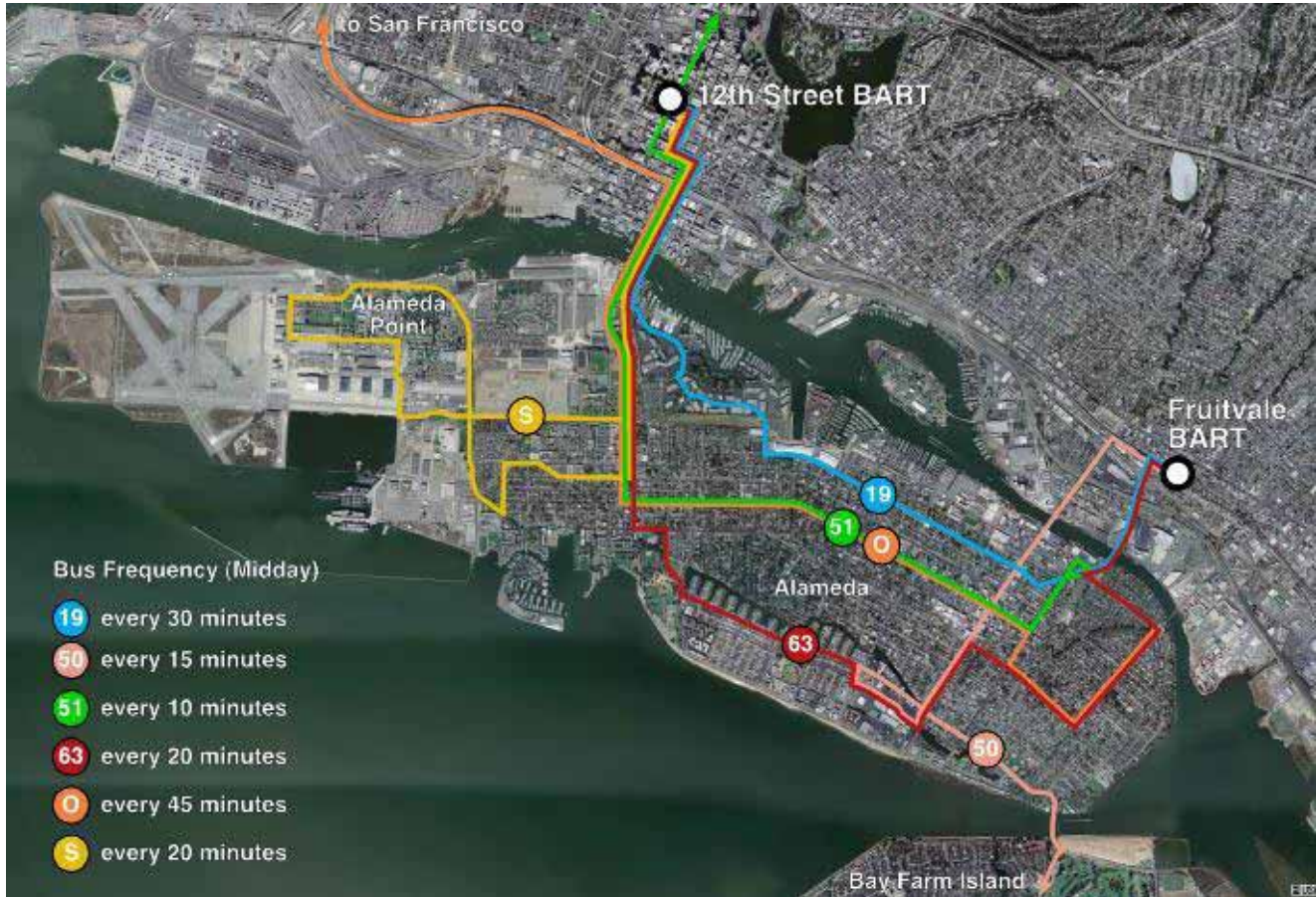

The City plans to incorporate queue-jumping lanes for transit into the Tinker Avenue and Mitchell-Mosely extensions. Queue jump lanes are lanes that allow transit vehicles to bypass congestion at critical intersections. On the approach to the tubes, these lanes will allow buses to move past the queue of motorists waiting at these two new intersections to minimize the time it takes to reach the tube. An additional set of queue jump lanes may also be desirable to the intersection Atlantic Avenue/Webster Street and the Beltline right-of-way may provide an opportunity to achieve queue jump lanes at this location. These recommended improvements are discussed further in the “mid term strategies” section.

Zero or Low Emission Transit Vehicles

Consistent with the Community Reuse Plan goal for a sustainable, environmentally sensitive development, the Alameda Point Transportation Strategy recommends use of low or zero emission transit vehicles whenever possible. The redevelopment and reuse of Alameda Point should incorporate sustainable, environmentally sound, energy and resource efficient site design, construction, landscaping, and transportation technologies. Reducing automobile trips and the environmental impacts of automobile trips is a central goal of the transportation strategy. Use of zero emission or low emission transit vehicles to replace internal combustion



Hybrid-Electric Bus

single occupancy vehicles would further reduce the impacts of Alameda Point redevelopment on the environment. For these reasons, the Transportation Strategy recommends electric battery or hybrid electric transit buses.

In addition to the cleaner air and reduced noise benefits, electric drive and hybrid-electric buses reduce fuel consumption. After labor costs, fuel cost is the second largest operating expense for transit agencies. Battery-electric buses are petroleum-free options (in terms of the onboard fuel), while hybrid buses are demonstrating fuel economy increases of 10% at a minimum and as much as 48% over a conventional diesel bus. If the Alameda Point transit program used zero emission, battery electric shuttles and buses, Alameda Power and Telecom (A.P.+T) would provide the electric power to charge the batteries. A.P.+T is a department of the City of Alameda and is committed to protecting the environment and promoting the use of clean power. Currently, 80% of the electricity provided by A.P.+T. to Alameda comes from renewable resources. More than half of this power is geothermal power generated in the steam fields of Northern California.

Alameda would not be the first to use of battery electric or hybrid electric transit vehicles. According to the U.S. Department of Transportation, in 2005 ten (10) cities in the United States have added five or more battery-electric powered transit vehicles to their public transit fleet. Three of the four largest programs with 10 or more battery-powered vehicles are located in California. Santa Barbara operates 20 battery electric vehicles, Los Angeles operates 18 vehicles, and Anaheim operates 10 vehicles. The Alameda Point transit program would require approximately five vehicles. Due to some of the operational flexibility provided by the hybrid electric technology, a larger number of transit agencies are incorporating hybrid electric transit vehicles into their fleets. According to the US Department of Transportation report, sixty cities in the United States are operating electric-hybrid transit vehicles.

Expanded Ferry Service

The transportation strategy recommends regular ferry service from a new town center ferry terminal adjacent to Seaplane Lagoon consistent with the Alameda Community Reuse Plan and the Bay Area Water Transportation Authority's (WTA) Regional Ferry Plan. More recent regional efforts also indicate a potential connection to a new South San Francisco Ferry Terminal from Alameda. These new ferry services would replace the current San Francisco service currently provided by the Oakland/Alameda ferry at the Gateway Ferry Terminal (although the ferry from Oakland's Jack London Square would remain).

In November of 2004, Bay Area voters passed Regional Measure 2 (RM2 providing funding for regional transportation improvements, including implementation of the Regional Ferry Plan. In order to be eligible for RM2 funds, the WTA must operate the new service. Routes eligible for these funds should be either new or enhanced service. Enhanced service includes increased frequency.

Bicycle Facilities

To encourage bicycle use, Alameda Point will offer the following bike services:

1. Alameda Point will be designed to foster a bicycle and pedestrian-friendly environment by including bicycle lanes and paths and pedestrian paths. The site signage program will be designed to accommodate pedestrians and bicyclists, as well as motorists.
2. The development will provide enough covered, enclosed bicycle parking in the commercial development area to accommodate 1.5% of the employee population commuting by bicycle. The development will also provide 50 to 100 short-term bicycle rack spaces in the commercial nodes.
3. The development will provide 1 shower and changing facility within ¼ mile of every commercial building.
4. The development will provide 1 clothing locker per 25,000 square feet of commercial building space. Lockers will also be large enough to hold roller blades.
5. The development will work with on-site fitness centers (if any) in the lease negotiations to provide shower and locker privileges free of charge to bicycle and pedestrian commuters.

Carsharing

The Transportation Coordinator will manage an on-site, car-share program. The car-share program is designed to provide cars to people who need them on an occasional basis. The cars will mainly be used on weekends (by site residents) and during weekday days (by site employees). Potential trip purposes include travel to a business meeting during the day and errands by residents during the evening or on weekends. Every effort will be made to offer energy-efficient vehicles for intra-island trips.

The number of vehicles available through the car-share program will increase over time as more employees and residents are located at Alameda Point. Figure 4 illustrates potential carsharing pod locations along with quarter-mile buffers for the smaller neighborhood centers and a half-mile buffer for the main transit terminal at the northeast corner of the Seaplane Lagoon.

Figure 4: Carsharing Pod Locations



Parking Strategies

Residents at Alameda Point will be offered the option to pay an additional amount for each off-street parking space they require beyond the first, which will be standard for all homes. Communicating the cost of additional off-street parking in this fashion will result in some residents choosing to save money by opting for a single off-street space, when two spaces per dwelling unit is the norm for most new developments.

Additionally, the homeowner's association at Alameda Point will be proactive in implementing and monitoring a residential parking permit program. On-street parking will have two-hour time limits for vehicles not displaying residential permit parking passes. Residents who wish to use on-street parking for more than two hours will also have the opportunity to purchase annual, daily or 14-day passes allowing long-term parking for residents and visitors. All residential streets will provide adequate width for on-street parking along at least one side of the street (both sides in most cases).

Guaranteed Ride Home

The Transportation Coordinator will work with tenant contacts to register all businesses for the Alameda County Guaranteed Ride Home (GRH) program. In addition, the Transportation Coordinator will make cars from the car-share fleet available for Guaranteed Ride Home Purposes, when they are not reserved for other purposes. When they are reserved, the Transportation Coordinator will rely on the County program.

Transportation Coordinator

Multiple tenants and residents will occupy Alameda Point. To facilitate implementation of this plan, the master developer will set up a management infrastructure to coordinate the different tenants, most importantly, an on-site individual in charge of organizing, marketing, and administering the program. Lessee/tenant and resident fees will fund the position, known as the Transportation Coordinator.

Each lessee/tenant will be required to designate an employee to serve as a point of contact for the Transportation Coordinator. Each lessee/tenant will cooperate with the Transportation Coordinator to share information about their employees that will be useful to TDM programming (e.g. employee home zip codes and/or cross-streets).

The Transportation Coordinator's marketing efforts will include:

1. Hosting and maintaining a web page with descriptions of all TDM programs, program forms, links to the regional rideshare agency's on-line ridematching system, transit/shuttle schedule information, and links to transit providers and 511.org.
2. Providing "stock" materials (i.e. materials prepared by other agencies) to tenants who will be responsible for distributing them to employees.
3. Producing customized materials that explain the TDM programs at Alameda Point and will distribute them to tenants who will be responsible for distributing them to employees on an on-going basis as well as at new employee orientations.
4. Having an office or "outlet" space in the main retail area of Alameda Point (or other central location) where employees can get information, pick up transit passes, etc.
5. Holding an annual carpool registration drive to get names into the rideshare matching database.
6. Hosting one annual transportation event, such as a transportation information fair or piggy-back on a regional transportation event sponsored by the Regional Rideshare Program.
7. Hosting a new employee orientation once a quarter.
8. Providing a quarterly on-line newsletter to tenants and their employees.

Marketing efforts will target all site employees, regardless of their origins. Marketing efforts alone can increase the number of employees using transportation alternatives about one percent. They also enhance the effectiveness of other measures. This enhancement becomes apparent when the remaining strategies in this plan achieve their high-end trip reduction estimates.

Mid-Term Strategies

Rapid Bus and Queue Jump Lanes

AC Transit is developing a network of improved bus services called “rapid buses.” A rapid bus line operates along San Pablo Avenue, providing faster trip times and attracting new riders to the service. Rapid bus service has been a big success in Los Angeles, with many lines now operating. Rapid bus service includes upgrades such as signal prioritization, where the bus can trigger a green light while a regular vehicle cannot, and improved bus stops that have shelters, seating, and sometimes real-time information about how long a passenger can expect to wait for the next bus. The stops for these buses are normally farther apart than for local buses. These improvements are relatively easy to construct and can be implemented incrementally.



AC Transit Rapid Bus

The most challenging component of the mid-term strategy is queue jump lanes on the Oakland side of the Estuary. As the initial phase of the project is completed and the homes become occupied from both Alameda Point and the Catellus development, congestion in the Tubes will continue to increase. Any transit strategy that relies on the Tubes to reach its destination, such as the shuttle or bus connection to Downtown Oakland or the Transbay Bus Service, will lose some effectiveness if it is subject to the same congestion as a single occupant vehicle (SOV). To combat this effect and to strengthen the overall transit service for the entire west end, the next phase of the transit strategy is to provide “queue jumping lanes” on the Oakland side of the tubes. These lanes allow transit vehicles to bypass congestion at intersections by creating additional transit-only lanes. Similar to the High Occupancy Vehicle (HOV) lanes on the approach to the Bay Bridge, these lanes would be constructed on either side of the tubes, but not in the tubes themselves.

On the Oakland side, initial concepts for queue jump lanes for buses to utilize as they enter and exit the tubes must be thoroughly considered as the impacts will be greater to Chinatown and Downtown Oakland. Any concepts must be compatible with the Broadway/Jackson Phase II project. This project is a partnership among the cities of Oakland and Alameda, Caltrans, the Alameda County Congestion Management Agency, and other stakeholders. Its main goal is to create a direct connection from the tubes to I-880. Thus far, none of the alternatives under discussion preclude the introduction of queue jump lanes on the Oakland side.

Long-Term Strategies

As Alameda, Oakland and the region continue to grow, the City will continue to work with stakeholders such as Oakland, AC Transit, the Water Transit Authority, and BART to build and improve transit services to Alameda Point and the West End. The long-term strategies will serve all of Alameda, not just Alameda Point. Based upon an evaluation of various alternatives (Appendix A) and the comments at the public workshops, this report identifies a limited number of long-term options for further study and discussion among the community and other stakeholders. Each of these options will require approval from a number of outside agencies, support from the City of Oakland, and significant funding commitments from State and Federal funding sources. However, based upon feedback from the Alameda community, these three options gathered the most support. The three options are: Bus Rapid Transit (BRT), Light Rail Transit/Streetcar (LRT), and Group Rapid Transit (GRT).

Bus Rapid Transit

A Bus Rapid Transit (BRT) system would represent a significant improvement to the existing AC Transit service in Alameda. Similar to the BRT system currently being built in Eugene, Oregon, an Alameda BRT system would provide a dedicated right-of-way for rubber tire transit vehicles and offer all the amenities of a light-rail system. This includes substantial sheltered stops with seating, real-time arrival displays, ticket machines to allow patrons to board through any bus door, traffic signal priority for buses, and dedicated lanes where feasible to keep the buses free from traffic congestion. Additionally, the vehicles themselves have the character of a light rail vehicle rather than a traditional bus.



BRT Vehicle in Eugene, OR

Throughout much of Alameda, the City has preserved much of the historic Beltline railroad right-of-way for transportation purposes. The former Beltline right of way could redevelop as a BRT right- of-way connecting Alameda Point and Alameda to the Fruitvale BART Station and/or the 12th Street BART station.

Crossing the Estuary and providing a dedicated right-of-way to the Oakland BART stations poses some unique challenges that require cooperation and partnerships with the City of Oakland, the Port of Oakland, the Coast Guard, Union Pacific, the transit agencies, and a host of other agencies with regulatory or permitting authority, such as the US Coast Guard, the Army Corps of Engineers, and the Bay Conservation and Development Commission.

A BRT connection to 12th Street BART with a dedicated right of way will require a new estuary crossing for transit and a dedicated right-of-way into downtown Oakland. An elevated drawbridge might provide the new crossing over the estuary and the Union Pacific (UP) tracks in Jack London Square. The BRT line would then need to drop down to street level at 5th Street after crossing the UP Tracks on the Embarcadero but before the I-880 freeway. The Jack London Square station in this alternative would be an elevated station requiring elevators, escalators and stairs, possibly connected to the Washington Street Parking Garage. The line would likely need to align with 5th

Street in Alameda and Clay and Washington Streets in Oakland. The drawbridge could allow bicycle and pedestrian access but would otherwise be transit-only.

Alternatively, a transit tube could provide a dedicated BRT right of way under the Estuary and under the UP tracks. Similar to the elevated alternative, the line would return to street level between the Embarcadero and 5th Street. In this alternative, the Jack London Station would be an underground station requiring stairs, escalators, and elevators. Under either alternative, to create a continuous, dedicated right-of-way would require the City of Oakland to redesign Clay and/or Washington Street to accommodate the BRT line.

Providing BRT to the Fruitvale BART station is slightly less difficult given that the former Alameda Beltline railroad included a dedicated right-of-way across the Fruitvale Bridge and into Oakland as far as the UP Tracks. To provide BRT to Fruitvale BART would require fairly significant upgrades and a seismic retrofit to the Fruitvale Bridge; use of the existing rail right of way to the UP tracks in Oakland; a crossing of the UP main line tracks; and a dedicated right-of-way for the last five blocks from the UP Main line into the Fruitvale Transit Village. The recently completed Fruitvale Transit Village would need to be modified to accommodate a BRT transfer station to BART.

Although there would be clear transit benefits of upgrading to a full BRT system, there are still many issues that would need to be resolved both within Alameda, as well as with the City of Oakland, Union Pacific and the transit agencies. However, one benefit of the BRT concept is that as funding is identified, the BRT system could be incrementally expanded across Alameda and into Oakland. For example, the BRT line might use a dedicated right of way in Alameda, utilize queue jumpers to exit and enter the tubes, but join the flow of traffic inside the tubes and on the Oakland city streets. This approach would avoid the very costly and potentially controversial improvements necessary to create a new dedicated transit crossing or “transit only” lanes in Oakland where they do not currently exist.

Light Rail Transit/Streetcar

Light Rail Transit (LRT) and/or Streetcars are familiar to most residents of Alameda. Streetcars operate along Market Street in San Francisco and formerly operated throughout Alameda. The LRT/Streetcar alternative includes all of the same crossing and right-of-way issues as the BRT option described above but at a significantly higher cost. (See Appendix A for cost information on the various alternatives.) In addition, crossing the UP main line at the Fruitvale BART Station with a light rail or street car will require either an elevated crossing or an underground crossing, according to Union Pacific.

While the community expressed interest in streetcars as a community-building element, this type of transit would require significant investments and higher ridership than the BRT in order to justify the amount of public subsidies that would likely be necessary to cover construction and operating costs. Nonetheless, LRT or streetcars are a natural progression from BRT. If the City is able to achieve separate rights-of-way for transit for the entire length of the island and crossing to Oakland, implementation of an LRT system might be feasible.

Group Rapid Transit

Group Rapid Transit describes a number of technologies that allow flexibility for riders. A passenger enters the Group Rapid Transit station; selects a destination; and waits for no more than six to seven minutes for a transit vehicle. If there are others with the same destination, the vehicle arrives in the station and carries the passengers directly to the final destination, bypassing stations in between. Otherwise, the vehicle carries a single passenger to the destination after the initial wait time. These technologies are computer operated generally without a driver. Due to the lower weight of the vehicle and the fact that it operates by computer, the construction and operating costs are projected to be less than a traditional light rail or streetcar system. However, for the same reasons, the system must be grade-separated from intersections, pedestrians, vehicles, or bicycles. Therefore a GRT system would require extensive above ground or underground infrastructure throughout both Alameda and Oakland. Currently, there are few Group Rapid Transit systems operating in the United States. The most prominent example is in Morgantown, West Virginia. As this technology matures and gains a foothold in other locations, the City may be interested in employing it in Alameda.

Group Rapid Transit

Group Rapid Transit describes a number of technologies that allow flexibility for riders. A passenger enters the Group Rapid Transit station; selects a destination; and waits for no more than six to seven minutes for a transit vehicle. If there are others with the same destination, the vehicle arrives in the station and carries the passengers directly to the final destination, bypassing stations in between. Otherwise, the vehicle carries a single passenger to the destination after the initial wait time. These technologies are computer operated generally without a driver. Due to the lower weight of the vehicle and the fact that it operates by computer, the construction and operating costs are projected to be less than a traditional light rail or streetcar system. However, for the same reasons, the system must be grade-separated from intersections, pedestrians, vehicles, or bicycles. Therefore a GRT system would require extensive above ground or underground infrastructure throughout both Alameda and Oakland. Currently, there are few Group Rapid Transit systems operating in the United States. The most prominent example is in Morgantown, West Virginia. As this technology matures and gains a foothold in other locations, the City may be interested in employing it in Alameda.

Section II: Transit Strategies Evaluation

TABLE OF CONTENTS

I. Transit Options Evaluation	2
A. Alignments.....	2
Figure 6: Transit Alignment Options	3
Fact Sheet: Shuttle Service to BART in Oakland	4
Fact Sheet: Expanded Ferry Service	6
Fact Sheet: AC Transit Bus Rapid Transit/Rapid Bus.....	8
Fact Sheet: Streetcar/Light Rail to BART in Oakland.....	10
Fact Sheet: Grade-Separated Transit to Oakland	12
Fact Sheet: Aerial Tramway to BART in Oakland.....	14
Fact Sheet: New Bridge or Tube Connecting to the Regional Highway System	16
Fact Sheet: Amphibious Crossing – Bus Barge or Amphibious Transit Vehicle	18

I. TRANSIT OPTIONS EVALUATION

The City of Alameda undertook a public process to evaluate various transit alternatives. The discussion also included one potential highway connection. This process included several public meetings, meetings with transit agencies, and discussions with other public agency stakeholders. The types of transit initially evaluated were:

- Shuttle Service to Downtown Oakland BART
- Expanded Ferry Service
- Bus Rapid Transit/Rapid Bus
- Underground Transit to Downtown Oakland BART
- Streetcar/Light Rail to Fruitvale BART or Downtown Oakland BART
- Aerial Tramway to Downtown Oakland BART
- New Auto Bridge or Tube
- Amphibious Bus Crossing

The surviving options recommended for implementation and/or further study by this report are:

- Shuttle Service to Downtown Oakland BART (provider and shuttle type to be determined)
- Expanded Ferry Service
- Bus Rapid Transit/Rapid Bus Streetcar/Light Rail to Fruitvale BART or Downtown Oakland BART

The eliminated options are:

- Underground Transit to Downtown Oakland BART
- Aerial Tramway to Downtown Oakland BART
- New Auto Bridge or Tube
- Amphibious Bus Crossing

The series of fact sheets for each option that follow illustrate the criteria used to evaluate each option and how well each one competed. These sheets, the criteria, and other information were displayed at several public workshops.

A. Alignments

Three key alignments were evaluated for attracting transit riders from Alameda Point, the West End, and the island as a whole. These three alignments are:

- ⇒ West End to West Oakland BART
- ⇒ West End to 12th Street BART/Downtown Oakland
- ⇒ West End cross-island to Fruitvale BART

Figure 6: Transit Alignment Options

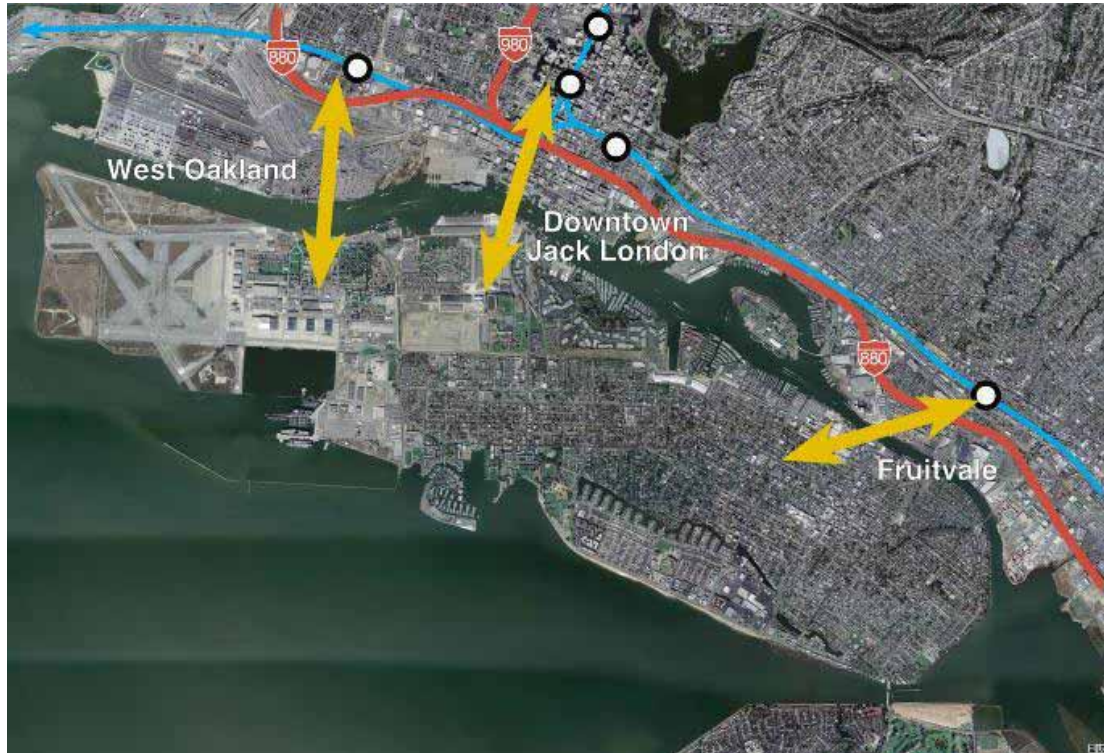

These alignments have potential because they tie into the regional transit system via BART. Residents of Alameda currently commute to three key locations: San Francisco, Downtown Oakland, and the South Bay. San Francisco and Downtown Oakland have the best potential to attract riders because they are major employment centers, charge for parking and are well-served by transit.

Connections to West Oakland BART, while offering the shortest travel times to BART from the West End, are problematic. Any connection must span the Port of Oakland. As a result, the connection must clear the cranes, which climb to upwards of 300 feet, the equivalent of a 30-story building. The Port has also expressed some security concerns related to having a public transit facility operating above their property, particularly in the post-9/11 environment.

The West End to 12th Street BART/Downtown Oakland connection provides a transfer to BART, as well as a connection to Downtown Oakland, which is a major employment destination. Finally, while the West End to Fruitvale BART is not ideal for residents of the West End, particularly if they are commuting to San Francisco or Downtown Oakland, it provides benefits for residents of the rest of the island for inter-island trips and connections to the Fruitvale BART station. The number of inter-island transit trips that could be achieved through a Fruitvale alignment would not likely justify the expense of this alignment, but there is strong community support for this alignment on the basis that it provides other urban design and place-making benefits.

These two alignments are still under discussion, with the understanding that options which provide island-wide benefits are more likely to attract widespread support. The City is also keenly aware that new long-term transit options, particularly those which require public funds, should provide regional benefits. Building partnerships with the City of Oakland, BART, AC Transit, and private developers on both sides of the Estuary increases the chances of success for long-term options.

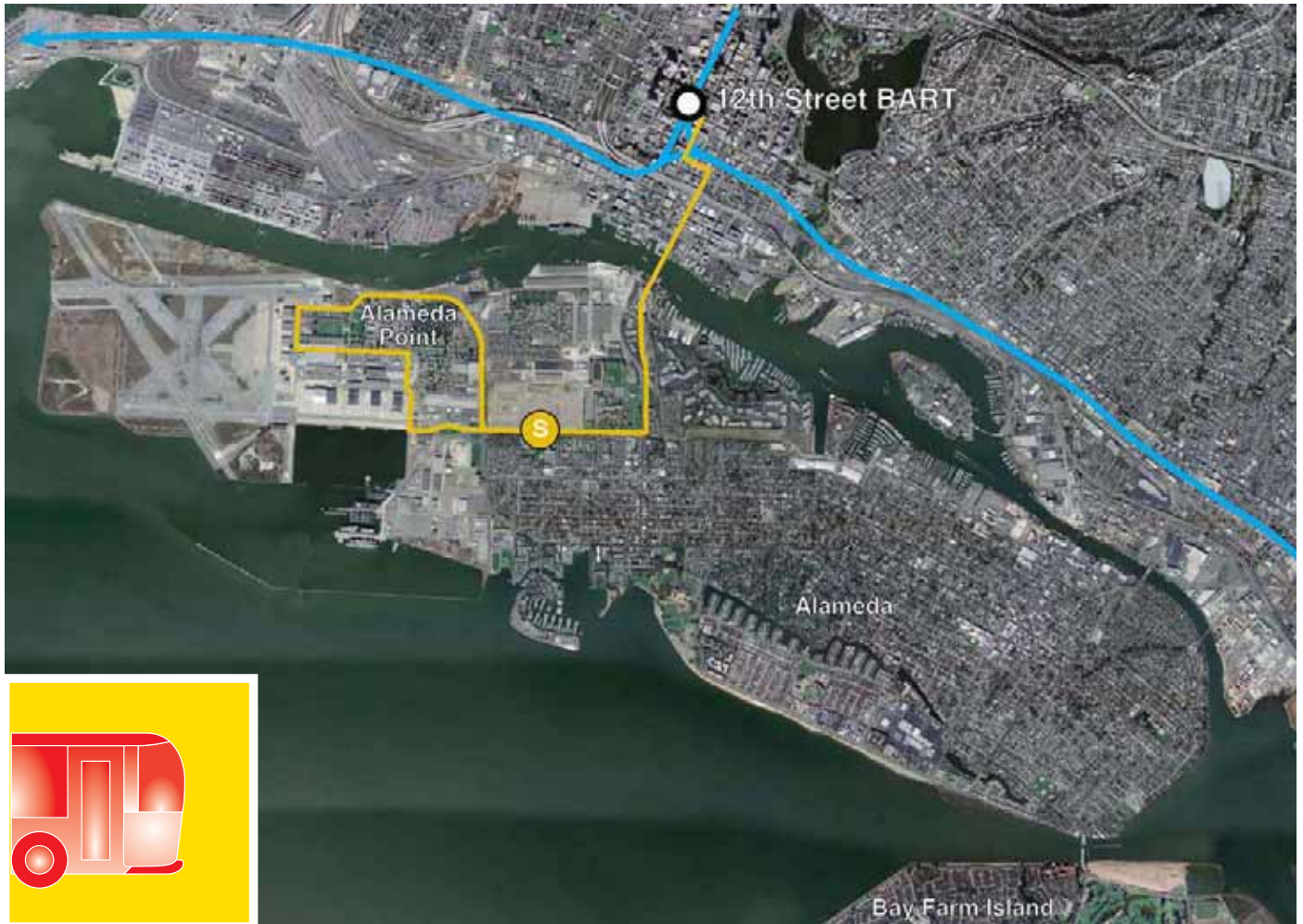

Shuttles operate where ridership is limited to peak hour trips, or where ridership is too low to support fixed-route bus line. Shuttles are also utilized where a private entity (rather than transit district) is funding the service so greater control can be exercised over the route and operations.

Shuttles can also provide the initial connection to BART and Central Alameda, before ridership grows large enough to support bus or other transit service. Frequency, routes and hours of operation of the shuttles can be tailored to match the demand as it grows with the development of Alameda Point. The services can also be easily adjusted as enhanced transit becomes available to connect Alameda Point to the regional transportation network.

Shuttle service to BART in Oakland

Benefits	Capacity Low	Low capacity is not a problem until significant development occurs at Alameda Point
	Travel Time Low - Medium	15 minutes from Alameda Point to 12th Street BART Can be affected by congestion in the tubes
	Ridership Potential Variable	Shuttle ridership would depend on the level of service offered and would be assumed to grow with the development of Alameda Point
	External Benefits None	None if limited to Alameda Point residents/employees



Typical shuttle vehicle



Vehicle interior

Cost	Capital Very Low	\$300,000 5 shuttle vans and route signage / stops
	Operations/Maintenance Low	\$400,000 annually for weekday service
	Funding Sources Identified	Developer City of Alameda
	Funding Availability Identified	City of Alameda has funding available



Emery-go-Round shuttle in Oakland

Implementation Complexity	Constructability N/A	No construction necessary
	Technological Established	Many local examples Many operators available
	Environmental Low Impacts	Possibility of reduction or elimination of parallel AC Transit service on Line 63
	Jurisdictional Minimal	Cooperation needed to establish stop locations on Alameda and Oakland streets



Typical shuttle vehicle





Expanded ferry service can move people from Alameda to San Francisco and other destinations without any impacts on the auto traffic crossing the estuary. A new ferry terminal is possible on the Seaplane Lagoon, replacing the existing Gateway Alameda terminal on the estuary. This would result in splitting the Alameda and Oakland ferry service into two direct routes, but would increase the operating cost for the remaining Oakland service.

Ferry service to San Francisco connects with all regional ferry lines. New service is planned by the regional Water Transit Authority to new terminals in South San Francisco and Redwood City. These new services may attract many new passengers.

Expanded Ferry Service

Benefits	Capacity Medium/High	1,200/hour (assumes 300 person ferry-15min headways) Capacity limited by access to terminal
	Travel Time Low	Alameda Point to San Francisco in 15 minutes
	Ridership Potential Medium/High	2,700 - 3,200 average daily riders 13% - 15% mode share
	External Benefits Low/Medium	Does not address trips into Oakland Connects to BART/transit in San Francisco



Current Alameda-Oakland ferry passing near Bay Bridge

Cost	Capital Low Cost	Additional ferries - \$4million each New Terminal - \$3-5million
	Operations/Maintenance Low/Medium	\$1.7m/year increase from existing
	Funding Sources Dedicated Regional Funds	RM 2 bridge tolls available for new ferry routes
	Funding Availability Available	Successful established service / local match? RM 2 bridge tolls available for ferry routes

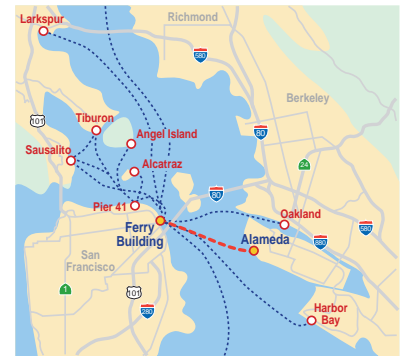

Bay Area ferry routes

Implementation Complexity	Constructability Easy	Existing terminal available New terminal can be built within near term
	Technological Established	Many local examples
	Environmental Few Impacts	Shoreline wake, exhaust, dredging Parking facilities in Alameda
	Jurisdictional Established process	Cities, WTA, Coast Guard, BCDC





AC Transit is developing a network of improved bus services. A “Rapid” bus line operates along San Pablo Avenue, providing faster trip times and attracting new riders to the service. Rapid bus service has been a big success in Los Angeles, with many lines now operating.

A BRT (Bus Rapid Transit) line is under development between Berkeley and San Leandro. Eugene, OR, is building a BRT system, where buses run in their own right of way, and offer all the amenities of a light-rail system.

Either concept could provide improved transit service to Alameda, at an affordable cost.

Initial plans contemplate splitting the existing AC Transit 63 Line into a Alameda Point line and a trans-Alameda line. Each would serve 12th Street BART. Service on each line would operate every 20 minutes. The Alameda Point line could operate as a shuttle or new AC Transit route.

AC Transit Bus Rapid Transit / Rapid Bus

Benefits	Capacity Medium - High	1,800 per hour Assumes one line with 10min headway
	Travel Time Low - Medium	14 minutes (existing 63 route) Can be affected by future congestion in the tubes
	Ridership Potential Medium - High	Proposal to divide existing 63 line into two lines with closer headways will improve service for Alameda Point and riders along 63 route in Alameda
	External Benefits Medium	Builds on existing AC ridership Can "jump-start" a new corridor



New high-capacity AC Transit Bus

Cost	Capital Low-Medium	\$3.5 - 23 million, depending on scope of improvements Low estimate assumes new buses and queue jump lanes High estimate assumes major street improvements
	Operations/Maintenance Low	\$1.6 million for new Alameda Point line If operated as part of existing service, incremental cost would be lower than a new line
	Funding Sources Identified	Developer, AC Transit City of Alameda
	Funding Availability Identified	City of Alameda has funding available Possible county sales tax availability



Busway under construction in Eugene, OR
Station and median views

Implementation Complexity	Constructability Easy	Minimal construction needed for Rapid Bus Street improvements for BRT could be phased
	Technological Established	Buses are the most common form of transit
	Environmental Low Impacts	Traffic impacts for BRT or priority at tubes
	Jurisdictional Minimal	Cities, Caltrans, AC Transit



Busway under construction in Los Angeles
Station and median views



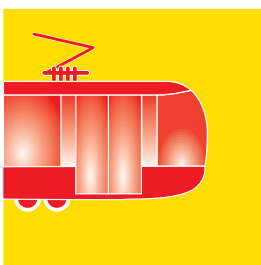
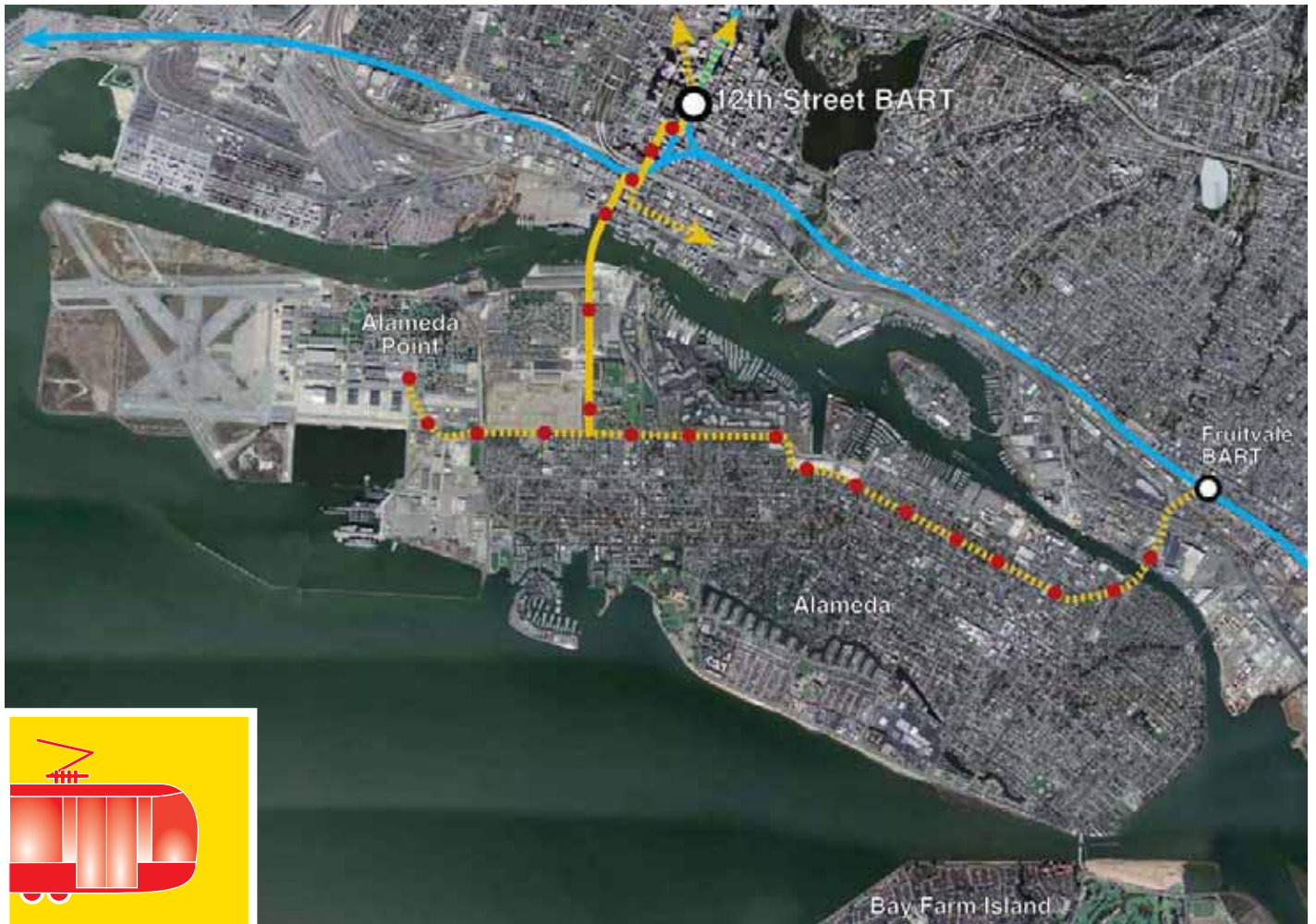

Oakland is considering a streetcar line between the City Center and Jack London Square. An extension to Alameda Point could be made, via a new lift bridge or tube. Previous studies have considered a light rail line from Alameda Point to Fruitvale BART station, utilizing the former rail right of way and lift bridge or West Oakland BART via a tube under the estuary, port, and railyards.

A new lift bridge near Jack London Square could be built for rail and buses, with access for pedestrians and cyclists, as well. The bridge would need to cross above the UPRR tracks, as well as the estuary.



Fruitvale Station



New Clay Drawbridge

Streetcar / Light Rail to BART in Oakland

Benefits	Capacity High	840/hour (140/streetcar - 10 minute headway)
	Travel Time Low/Medium	Partially dedicated right of way 15 minute trip to 12th Street BART 20 minute trip to Fruitvale BART
	Ridership Potential High	2,000 - 3,000 riders from Jack London area Total ridership with Alameda project depends on alignment chosen and integration with AC Transit service
	External Benefits High	Local Oakland trips Extensions to other destinations Possible trans-Alameda service



Streetcar in downtown Portland, OR

Cost	Capital High	12th Street - \$222 - \$242 million Fruitvale - \$202 - \$222 million
	Operations/Maintenance Medium	12th Street - \$6.8 million / year Fruitvale - \$8.4 million / year
	Funding Sources Unknown	Developer, BART, unknown
	Funding Availability Unknown	Regional support needed MTC criteria for new rail projects looks at land use as part of prioritization for regional funds



Light rail in Portland, OR

Implementation Complexity	Constructability Medium	Bridge/tube must also cross UPRR tracks Integration with auto/bus traffic in Oakland Terminal at Fruitvale BART is challenging
	Technological Established	Many examples worldwide
	Environmental Medium Impacts	Street operations in Oakland Visual impact Estuary traffic affected by drawbridge operations
	Jurisdictional Multiple Approvals	Cities, Port, Coast Guard, BCDC, UPRR, PUC





Alameda could be brought into the region's trunk transit system by building a high-capacity grade-separated transit system across the estuary. Proposals exist for a BART shuttle from 12th Street station to a new station under the estuary, serving both Jack London Square and Alameda. This could be the first phase of a new tube under the bay to San Francisco.

Cybertran, based in Alameda, is in the process of developing a high-capacity personal rapid transit system. It is under consideration to link the terminals at Oakland International Airport with the remote parking lots. This system could be extended the length of Alameda and into downtown Oakland.

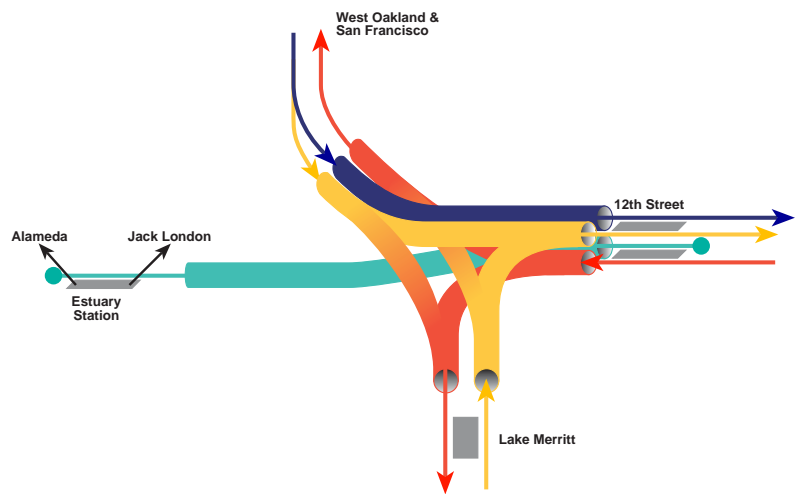

Grade-Separated Transit to Oakland

Benefits	Capacity High	Cybertran - 1,440/hour BART shuttle - 1,260 (3 car) to 4,200 (10 car)/hour* (capacity constrained by connection within Alameda)
	Travel Time Low - Medium	Cybertran, low travel time BART, medium - necessary transfer to shuttle at estuary station for trip into Alameda
	Ridership Potential Medium/High	3,000 - 4,000 riders for Jack London-only station. Possibly doubled with Alameda access
	External Benefits High	Cybertran demonstration project Tourist attraction Initial portion of new BART crossing



Cybertran on test track in Alameda
www.cybertran.com

Cost	Capital High	\$280-400 million for under Estuary station
	Operations/Maintenance High	\$2-4 million annual cost
	Funding Sources Unknown	Developer, BART, unknown
	Funding Availability Low	Unknown, not in regional transportation plan Would require regional consensus to move forward



BART train at West Oakland station

Implementation Complexity	Constructability Unknown	Cybertran still untested in service Station under estuary very complex to build Tunneling into 12th Street difficult
	Technological Varies	Cybertran still untested in service BART as shuttle overbuilt?
	Environmental Medium Impacts	Visual/sound impacts for Cybertran elevated portions Estuary station construction
	Jurisdictional Multiple Approvals	Cities, Port, Coast Guard, BCDC, UPRR, PUC



Lower level of BART's 12th Street station



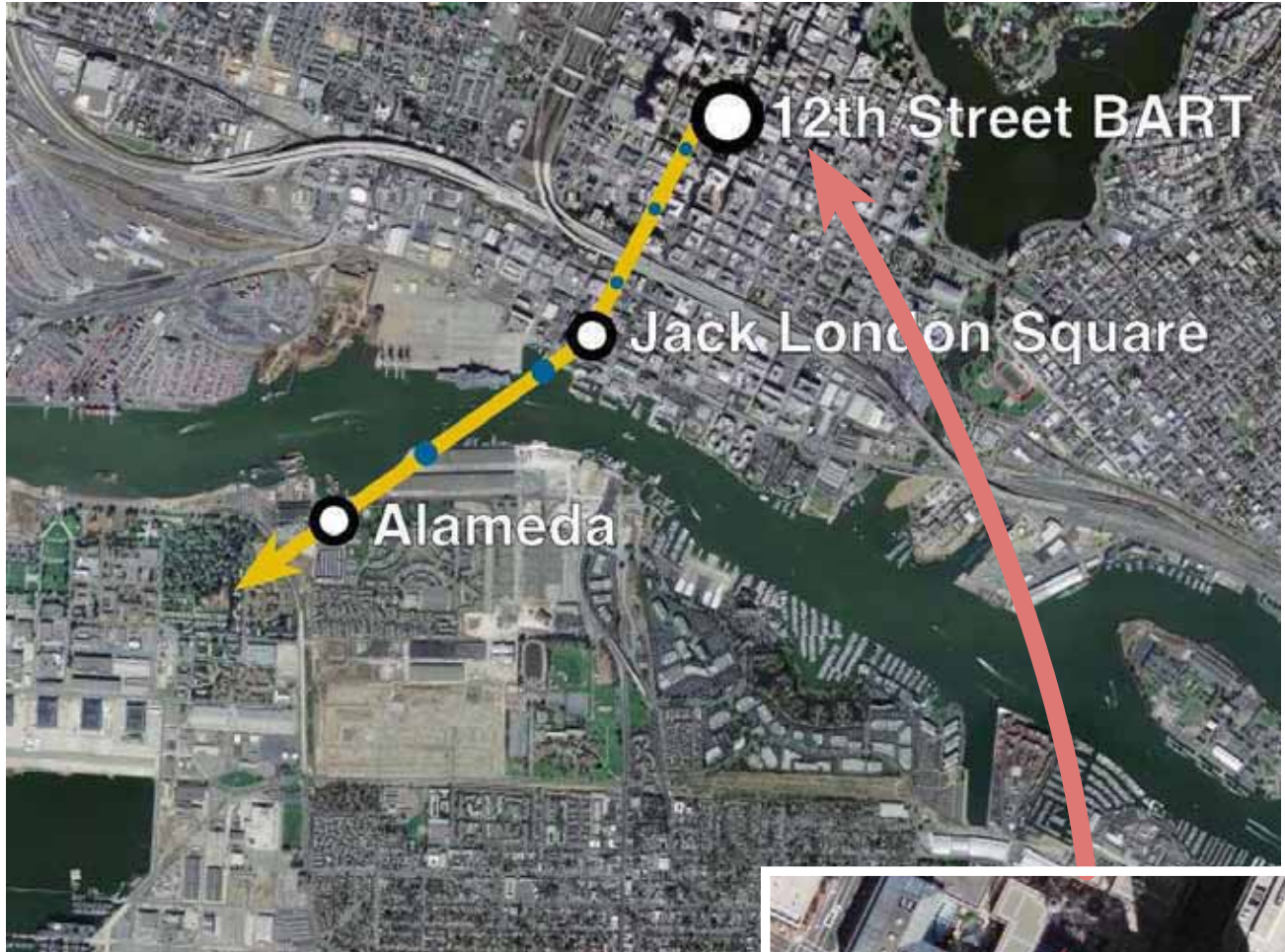

Blue dots show potential support tower locations

An aerial tramway system is under consideration to provide a transit connection between Alameda and BART in Oakland. An aerial gondola is a series of vehicles suspended from a cable which is hung from tall towers. The cable is pulled in a loop between end stations. An aerial tramway system has been operating as part of New York's transit system since 1976. Portland, Oregon is also building an aerial tramway for transit use.

A connection to West Oakland BART is possible, but a connection to 12th BART in Downtown Oakland forms a connection to the city center, a major interchange in AC Transit's network, along with BART. A station at Jack London Square would be included as part of either route.

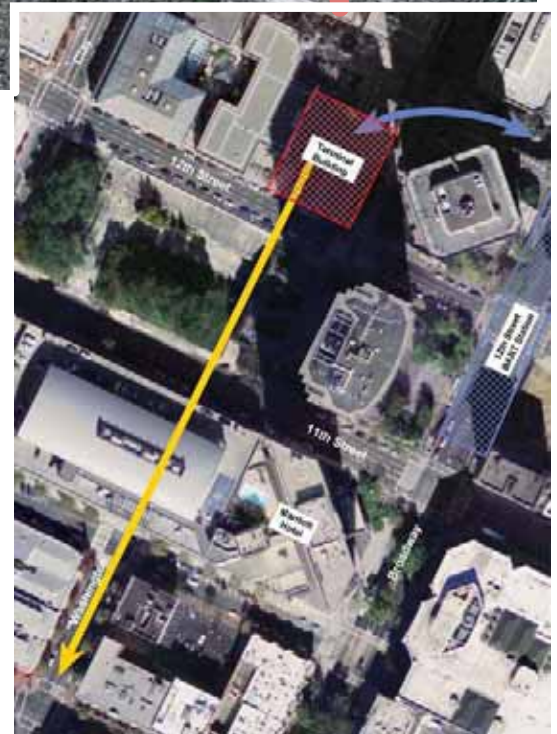

Aerial Tramway to BART in Oakland

Benefits	Capacity Very High	3,000 passengers/hour
	Travel Time Low - Medium	16 minutes to Downtown Oakland 18 minutes to West Oakland BART 42 minutes to San Francisco via BART
	Ridership Potential Medium	2,500 average daily riders
	External Benefits Medium	Tourist attraction Connection to Jack London Square

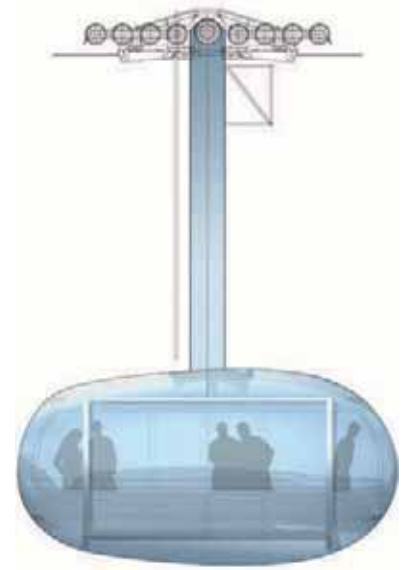

Rendering of proposed Portland Aerial Tram. For more information on the Portland project, www.portlandtram.com

Cost	Capital Low	\$45-52 million -Downtown Oakland via Jack London Square (includes \$10million for terminal site in Oakland) \$35-42 million to West Oakland BART
	Operations/Maintenance Low - Medium	\$1.5 million annually
	Funding Sources Unknown	Developer, unknown
	Funding Availability Unknown	Unknown, not in any current regional funding plan. Relatively low cost can possibly be covered by all local funds, eliminating need to compete at regional level.



Simulation of Oakland tramway terminal in City Center

Implementation Complexity	Constructability Medium Difficulty	Tower foundations in Bay Mud Cable installation over Estuary, Freeway, Streets BART interface
	Technological Established	Many recreational examples worldwide Few transit examples
	Environmental Medium Impacts	Visual Impact ADA Compliance
	Jurisdictional Multiple Approvals	Cities, Port, Caltrans, Coast Guard, BCDC, FAA



Simulation of tramway over Washington St.



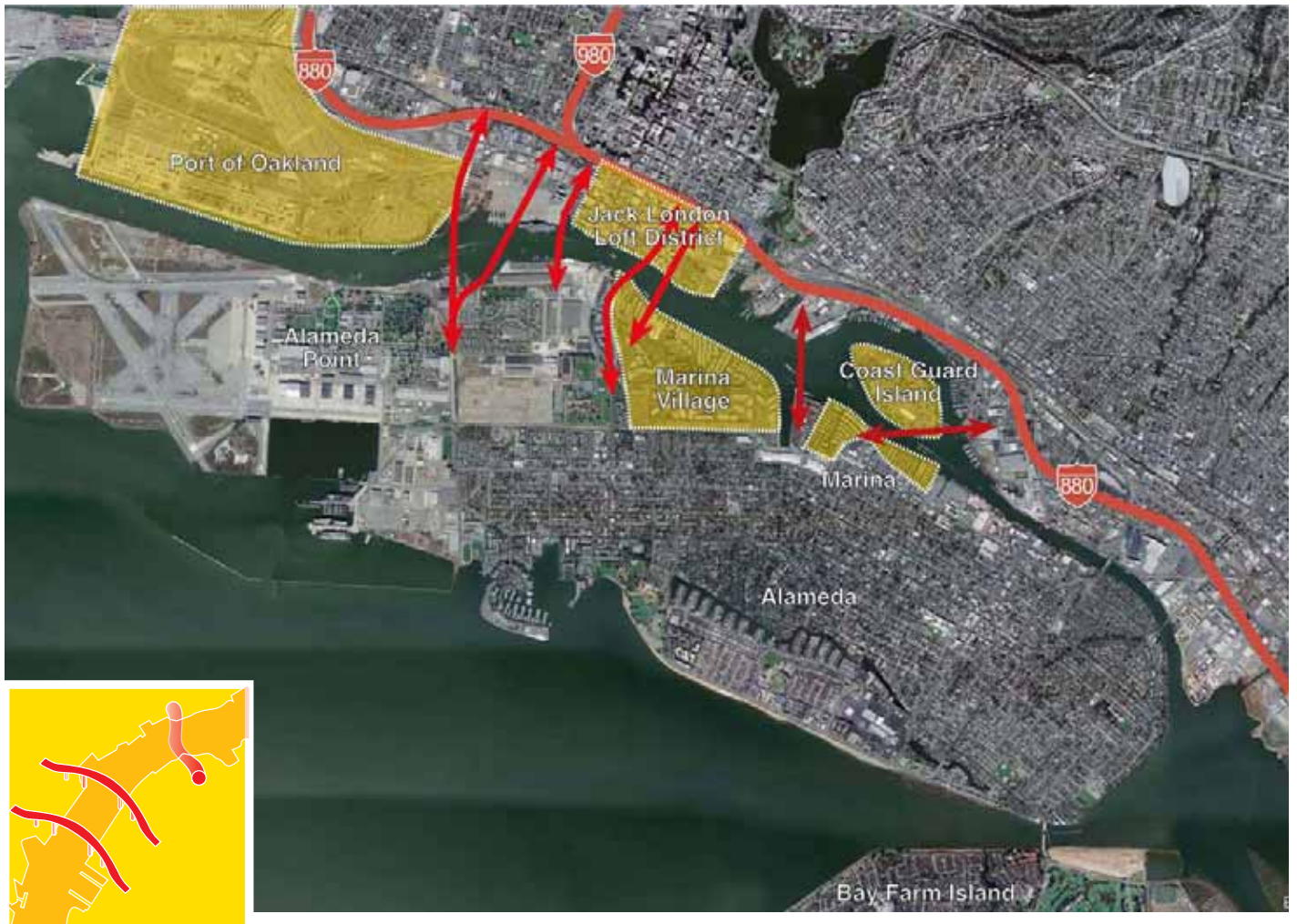

Highway solutions, either a bridge or a tube, will require improved access to the regional freeway system. This will most likely require right of way acquisition and new ramps to the I-880 and possibly I-980 freeways in the City of Oakland.

New bridges would need to pass higher than 135 feet over the estuary, requiring long approach ramps on each shore. If a lift span is substituted, the clearance is only 45 feet. A new tube or tunnel is estimated to cost more than a bridge.

New Bridge or Tube connecting to the regional highway system

Benefits	Capacity High	2,800 vehicles per hour HOV lanes possible for transit
	Travel Time Low	Alameda Point to I-880 - 5 to 10 minutes
	Ridership Potential Unknown	N/A - New traffic model would need to be built to study diversion of existing tube trips to new crossing and latent demand for additional capacity
	External Benefits Low	Provides back-up for access for existing tubes

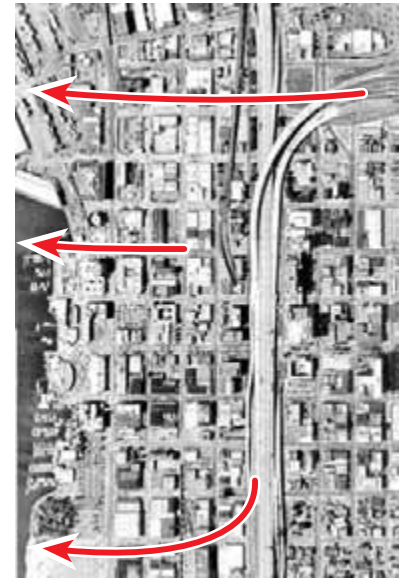

I-880 in the Jack London Square area with possible crossing options

Cost	Capital Very High	High Level Bridge - \$200 million + freeway ramps Lift Bridge - \$300 million + freeway ramps Tubes - \$600 - \$1,200 million (includes ramps)
	Operations/Maintenance Low - Medium	If part of state highway system, covered by Caltrans
	Funding Sources None	Unknown, no possibility for tolls unless tolls imposed on other estuary crossings
	Funding Availability None	Unknown, not in any current regional funding plan Very large funding requirement



1966 plan to extend I-980 across the estuary and onto a new bay crossing

Implementation Complexity	Constructability Medium Difficulty	Construction under/around active railway line Bay mud and excavation disposal Property acquisition for approaches
	Technological Established	Many examples
	Environmental High Impact	ROW requirements, visual impacts, water quality Added traffic capacity onto Alameda
	Jurisdictional Multiple Approvals	Cities, Port, Caltrans, Coast Guard, BCDC, FAA



Coronado Bridge in San Diego





A bus barge could transport regular buses across the estuary. The barge would encounter water traffic during its crossing, but earlier studies have estimated that two barges would be sufficient to allow 10-15 minute headways on the bus line they serve.

A "Duck" (DUKW or Lark) vehicle, essentially a boat with wheels, could drive on streets and then motor across the estuary. The Duck is untried in a transit setting. An amphibious vessel would need to be fully accessible to persons with disabilities. Current duck vessels are accessed via a ladder, resulting in very slow and cumbersome boarding and alighting. Overcoming this disadvantage will be a challenge.

Amphibious crossing - Bus barge or amphibious transit vehicle

Benefits	Capacity Low - Medium	Barge headway constrains bus option Loading procedure constrains Duck capacity
	Travel Time Low - Medium	Union Pacific RR crossing in Oakland hurts reliability Both options avoid tube congestion Complicated loading procedure slows Duck trip times
	Ridership Potential Unknown	Unknown Railway crossing delays would cause significant delays
	External Benefits Unknown	Tourist attraction



Duck tour boat operating in Florida

Cost	Capital Low	Capital cost undeveloped due to low probability of adoption of this alternative
	Operations/Maintenance Unknown	Unknown Duck maintenance specialized and expensive
	Funding Sources Unknown	Developer, unknown
	Funding Availability Unknown	Unknown Relatively low-cost alternative for options that avoid tubes



Vehicle ferry in the California Delta

Implementation Complexity	Constructability Low with challenges	Launch facilities along estuary Boarding platforms for Duck option? Accessible Duck possible?
	Technological Unknown	Many recreational examples worldwide No transit examples Boarding needs to be explored for Duck boats
	Environmental Medium Impacts	ADA compliance unknown Water quality, air quality, visual impact of ramps/docks
	Jurisdictional Multiple Approvals	Cities, Port, Caltrans, Coast Guard, BCDC



Duck boats in Daytona, Florida
www.trolleyboat.com



SECTION III – Travel Demand Forecasting Report

Table of Contents

I. INTRODUCTION	3
A. STUDY PURPOSE	3
B. REPORT ORGANIZATION	3
C. STUDY INTERSECTIONS	7
D. ANALYSIS METHODOLOGY	10
1. <i>Level of Service Criteria</i>	10
2. <i>Signalized Intersections</i>	10
3. <i>Unsignalized Intersections</i>	10
4. <i>Significance Criteria</i>	12
II. EXISTING CONDITIONS	12
A. STUDY AREA	12
B. EXISTING TRAFFIC COUNTS.....	14
C. INTERSECTION LEVELS OF SERVICE	15
III. TRANSPORTATION ANALYSIS	17
A. PROPOSED ROADWAY NETWORK.....	18
B. CUMULATIVE (YEAR 2025) LAND USE ASSUMPTIONS	21
C. TRAFFIC ESTIMATES.....	21
1. <i>Trip Generation</i>	21
2. <i>Trip Distribution and Assignment</i>	25
3. <i>Buildout (2025) Traffic Volumes</i>	30
D. INTERSECTION LEVELS OF SERVICE	34
IV. CONCLUSIONS AND RECOMMENDATIONS	35
A. RECOMMENDED STREET LAYOUT	35
B. RECOMMENDED INTERSECTION CONFIGURATIONS	36

Table of Figures

FIGURE 1 – STUDY LOCATION..... 5

FIGURE 2 – SITE PLAN..... 6

FIGURE 3 – EXISTING ROADWAY NETWORK AND STUDY INTERSECTIONS IN ALAMEDA 9

FIGURE 4 – EXISTING CONDITIONS – TRAFFIC VOLUMES.....16

FIGURE 5 – PROPOSED ROADWAY NETWORK.....19

FIGURE 6 – PROPOSED ROADWAY STUDY INTERSECTIONS.....20

FIGURE 7 – TRIP DISTRIBUTION (RETAIL)26

FIGURE 8 – TRIP DISTRIBUTION (OFFICE)27

FIGURE 9 – TRIP DISTRIBUTION (RESIDENTIAL).....28

FIGURE 10 –TRIPS EXTERNAL TO ALAMEDA POINT31

FIGURE 11 – FUTURE ROADWAY GEOMETRY.....32

FIGURE 12 – CUMULATIVE PLUS BUILDOUT CONDITIONS PEAK HOUR VOLUMES33

FIGURE 13 – PROPOSED MAIN STREET DESIGN36

FIGURE 14 – PROPOSED CONCEPT DESIGN OF ATLANTIC AVENUE/WEBSTER STREET39

FIGURE 15 – PROPOSED CONCEPT DESIGN OF ATLANTIC AVENUE/MAIN STREET.....40

FIGURE 16 – PROPOSED CONCEPT DESIGN OF TINKER AVENUE/MAIN STREET41

FIGURE 17 – PROPOSED CONCEPT DESIGN OF MITCHELL-MOSELY AVENUE/MAIN STREET

42

I. INTRODUCTION

This chapter discusses the study purpose, organization of this report, and the methodology used to forecast the travel demand that would be generated by the proposed redevelopment of Alameda Point, determine the net increase in off-site vehicle trips and develop the resulting level of service (LOS) for vehicle traffic at study intersections.

A. Study Purpose

The purpose of this report is to present the findings and recommendations of a travel demand forecast and transportation impact analysis conducted by Fehr & Peers for key intersections and roadways that provide access to the proposed redevelopment at Alameda Point.¹ The intersections chosen for the current analysis are included because they are each under consideration for significant changes in the form of lane reductions or dedicated right-of-way for transit.

More specifically this report addresses the following:

- Alameda Point trip estimates for Phase I (2010) and buildout (2025) including trip generation, internal capture rates, Transportation Demand Management reductions, and net new external trips
- Alameda Point trip estimates for key roadways: Webster and Posey Tubes, Atlantic Avenue, Tinker Avenue, Mitchell-Mosley Avenue
- Recommended street cross-section for Main Street
- Recommended configurations for the intersections of: Main Street/Atlantic Avenue, Main Street/Tinker Avenue, Main Street/Mitchell-Mosley Avenue, Atlantic Avenue/Webster Street

B. Report Organization

This report is divided into five chapters as described below:

Chapter I – Introduction discusses the purpose and organization of this report.

Chapter II – Existing Conditions describes the operating conditions of select intersections and roadways in the vicinity of Alameda Point, including, weekday AM and PM peak-hour traffic volumes, and intersection levels of service.

Chapter III – Alameda Point Transportation Conditions Phase I presents relevant information with respect to transportation impacts, such as estimated trip generation, geographic distribution of new trips, and trip assignment to the roadway network for Phase 1 of the Preliminary Development Concept (PDC).

Chapter IV –Transportation Conditions Buildout presents information similar to Chapter III, but for Alameda Point buildout projected to occur in the year 2025.

¹ This report updates some of the information presented in the *Alameda Point Travel Demand Forecasting Report* (Fehr & Peers, 2003).

Chapter V – Conclusions and Recommendations summarizes the results of the analysis and presents recommendations for intersection and roadway configurations and improvements.

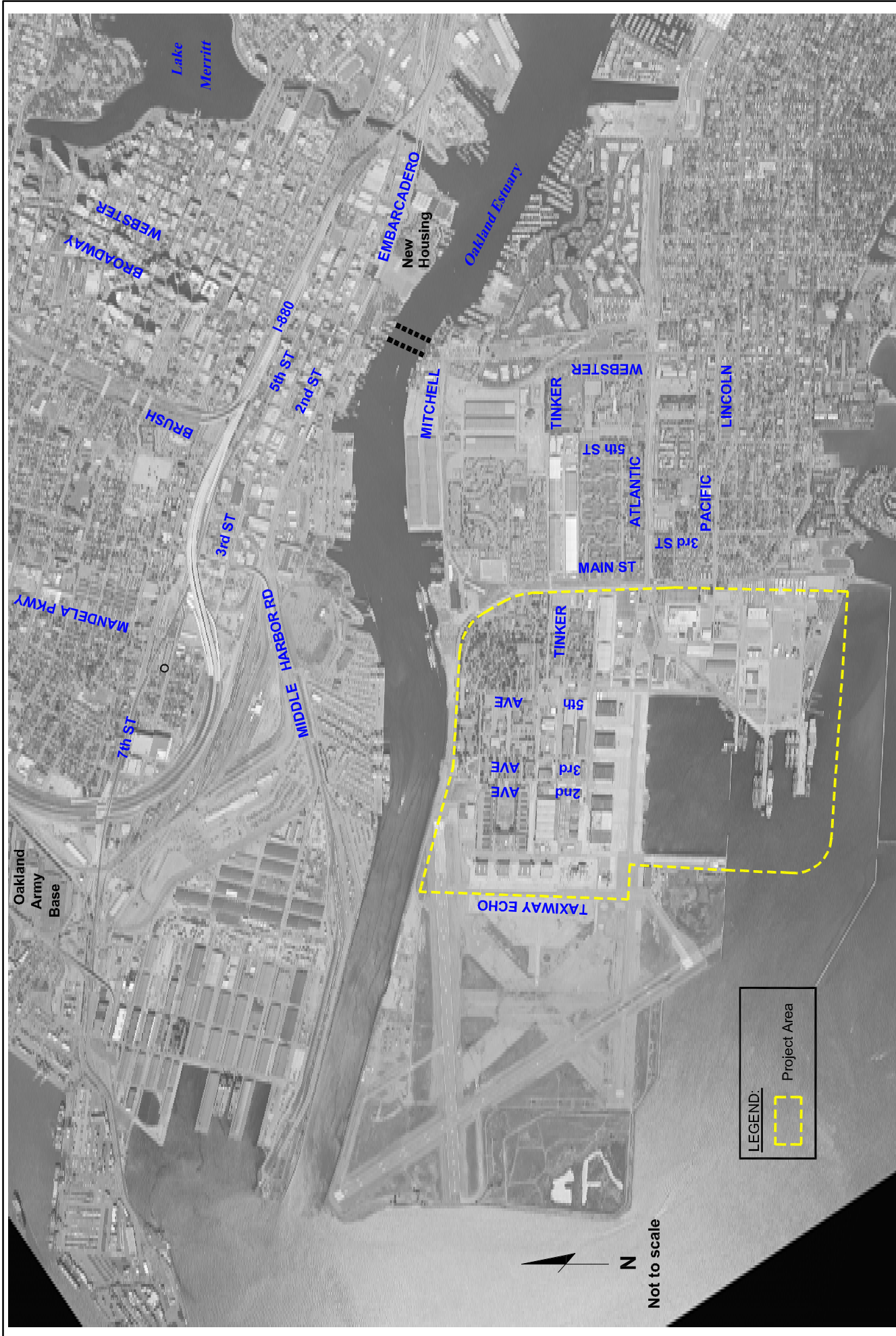

FIGURE 2 – SITE PLAN



Source: Roma Design Group, 2005

C. Study Intersections

The most common method of analyzing traffic impacts is to examine operations of key intersections near the proposed development. This study will analyze a total of six study intersections that will provide the primary access to Alameda Point. Intersections one through five are existing intersections. The intersection of Main Street / Mitchell-Mosley Avenue (Intersection 6) would be a new intersection created by the extension of Mitchell-Mosley Avenue. The locations of existing intersections are shown on Figure 3, and the proposed future roadway network and new study intersections are shown on Figures 5 and 9.

- 1) Atlantic Avenue / Main Street
- 2) Atlantic Avenue / Poggi Street
- 3) Atlantic Avenue / Webster Street
- 4) Main Street / Pacific Avenue
- 5) Main Street / West Midway Avenue
- 6) **Main Street / Mitchell-Mosley Avenue**

The six intersections were selected for this phase of planning to assist the City in answering critical questions about roadway configurations and the feasibility of a dedicated right-of-way for future Bus Rapid Transit or fixed rail as recommended in the *Transportation Strategy Report (2005)*.

The 2003 *Alameda Point Travel Demand Forecasting Report* identified critical intersections that are likely to remain critical in the forthcoming EIR. The table below, published in the earlier report, presents existing and cumulative level of service for the 31 intersections²:

Table 1 Intersection Levels of Service Cumulative (Year 2020) Plus New Land Uses at Alameda Point						
No.	Intersection	Traffic Control	Existing (Delay: Sec. / Veh.)		Cumulative Plus new Land Use (Delay: Sec. / Veh.)	
			AM Peak Hour	PM Peak Hour	AM Peak Hour	PM Peak Hour
1	Atlantic Avenue / Main Street	Traffic Signal ¹	B (12.1)	C (20.9)	C (34.6)	C (32.1)
2	Atlantic Avenue / Third Street	Traffic Signal	B (12.0)	B (12.3)	A (9.6)	A (9.1)
3	Atlantic Avenue / Poggi Street	Traffic Signal	A (7.9)	A (7.4)	A (7.0)	A (6.7)
4	Atlantic Avenue / West Campus Drive	Traffic Signal	A (9.4)	A (9.4)	C (32.1)	C (24.3)
5	Atlantic Avenue / Webster Street	Traffic Signal	D (35.1)	D (44.5)	D (48.0)	E (76.1)
6	Atlantic Avenue / Constitution Way	Traffic Signal	D (37.7)	D (41.5)	F (236.0)	F (88.0)
7	Constitution Way / Marina Village Parkway	Side-Street Stop-Controlled	B (14.5)	B (15.0)	B (14.6)	C (16.4)
8	Main Street / Pacific Avenue	Traffic Signal	A (7.4)	B (10.3)	A (9.8)	D (44.0)

² The counts used for this previous analysis were conducted between 2000 and 2002. New counts will be taken at most locations for subsequent EIR-level analysis.

9	Webster Street / Lincoln Avenue	Traffic Signal	A (8.6)	A (8.2)	B (10.0)	A (9.1)
10	Constitution Way /Lincoln Avenue	Traffic Signal	C (28.5)	C (26.2)	D (48.3)	D (41.4)
11	Webster Street / Central Avenue	Traffic Signal	B (15.7)	B (14.5)	B (19.9)	B (15.6)
12	Central Avenue /Eighth Street	Traffic Signal	C (26.5)	C (31.3)	E (79.1)	D (39.3)
13	Pan Am Way / Atlantic Avenue	Roundabout ²	A (7.4)	A (6.8)	A (8.7)	A (9.6)
14	Main Street / West Tower Avenue	AWSC ³	B (11.5)	A (8.6)	B (14.4)	C (19.0)
15	Main Street / West Midway Avenue / Tinker Avenue	Signalized ⁴	A (2.8)	A (4.3)	D (39.6)	D (37.4)
16	Main Street / Singleton Avenue	Side-Street Stop-Controlled	B (12.1)	A (9.7)	A (8.9)	A (8.9)
17	Main Street / Navy Way	Side-Street Stop-Controlled	A (0.0)	A (0.0)	A (0.0)	A (0.0)
18	Pan Am Way / West Midway Avenue	AWSC	A (7.7)	A (7.0)	B (11.3)	A (8.0)
19	Webster Street / 7 th Street	Traffic Signal	A (8.6)	A (9.9)	B (10.3)	A (9.7)
20	Harrison Street / 7 th Street	Traffic Signal	A (8.0)	A (8.8)	A (8.0)	C (30.6)
21	Jackson Street / 6 th Street	Traffic Signal	D (36.8)	C (30.6)	F (92.5)	F (120.3)

Notes:

¹ Signalized intersection LOS based on average intersection delay, based on the methodology in the *Highway Capacity Manual*, 2000 Edition.

² The SIDRA software was used to analyze the proposed single-lane roundabout. The methodologies used in this software are consistent with the methodologies contained in the *Highway Capacity Manual*, 2000 Edition. The LOS reported indicates the approach with the highest delay. Existing lane configuration and control was used for the existing LOS.

³ All-way stop-controlled (AWSC) intersection LOS based on average intersection delay, based on the methodology in the *Highway Capacity Manual*, 2000 Edition.

⁴ Under Cumulative conditions, this analysis assumes a traffic signal will be installed as part of the Tinker Avenue Extension.

Source: Fehr & Peers, June 2003.

The four intersections which failed under the previous analysis (Atlantic Avenue/Webster Street, Atlantic Avenue/Constitution Way, Central Avenue/8th Street, and Jackson Street/6th Street, which is in Oakland), will likely continue to be critical even though the land use description has changed. The subsequent Environmental Impact Report will require new counts and analysis based on the City of Alameda Traffic Impact Study Guidelines.

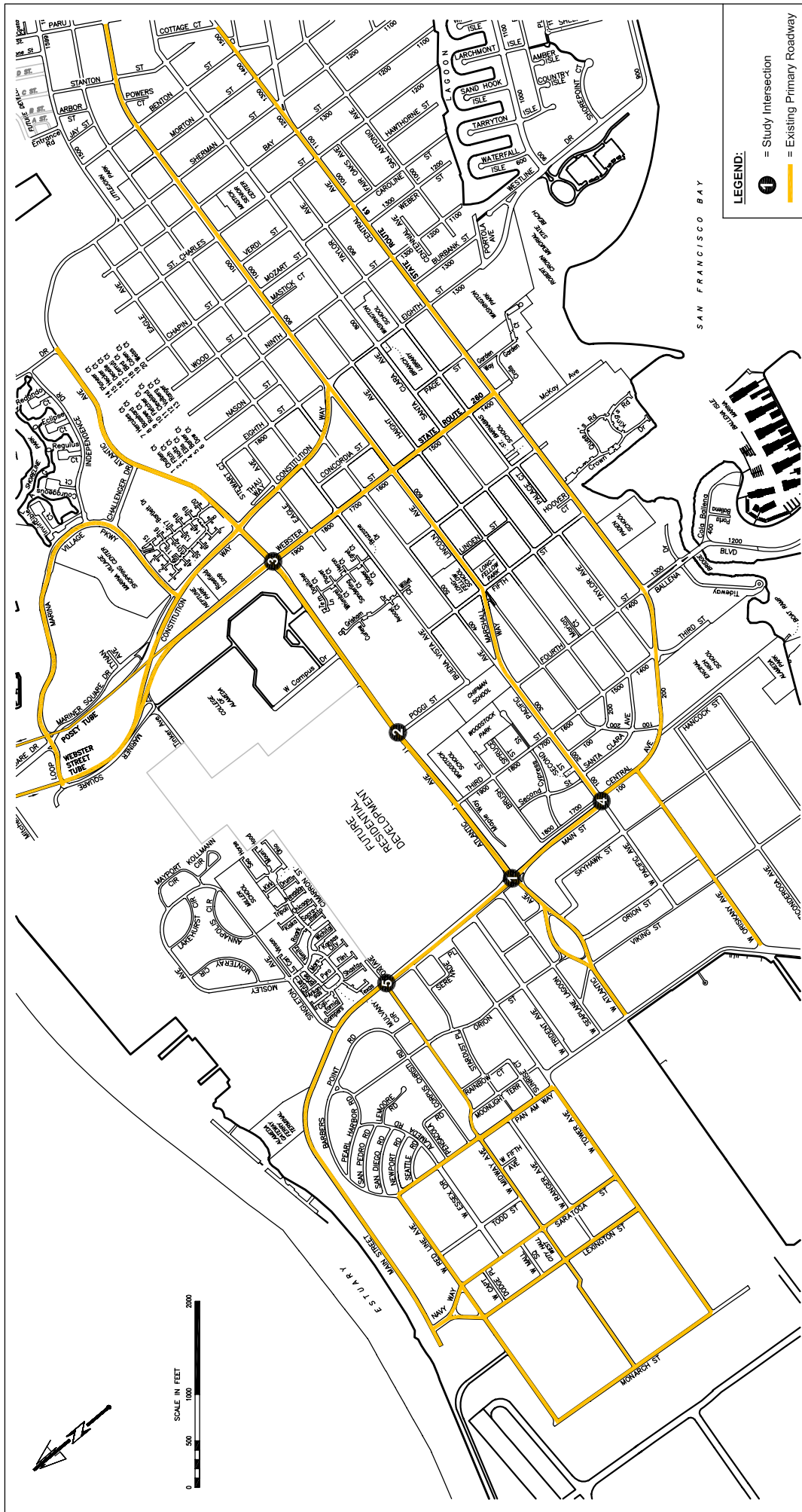

Alameda Land Use Planning
**EXISTING ROADWAY NETWORK
 AND STUDY INTERSECTIONS IN ALAMEDA**
 FIGURE 3

D. Analysis Methodology

The analysis methodology outlined in the *2000 Highway Capacity Manual* (HCM), published by the Transportation Research Board, was utilized for the analysis of intersection operating conditions.

1. Level of Service Criteria

To measure and describe the operational status of the local roadway network, transportation engineers and planners commonly use a grading system called level of service (LOS). LOS is a qualitative description of an intersection's operation, ranging from LOS A (indicating free-flow traffic conditions with little or no delay) to LOS F (representing over-saturated conditions where traffic flows exceed design capacity, resulting in long queues and delays).

2. Signalized Intersections

At signalized intersections, traffic conditions are evaluated using the methodology described in Chapter 16 of the *2000 Highway Capacity Manual* (HCM). This methodology determines the LOS rating based on the average "control delay" experienced at the intersection (in seconds per vehicle). "Control delay" refers to the delay imparted to vehicles by a traffic control device (a traffic signal or a stop sign). This "control delay" includes delay caused by a vehicle's initial deceleration at a signal, queue move-up time, stopped delay, and final acceleration. The ultimate result of "control delay" is the difference in travel time that a vehicle actually experiences versus the travel time that a vehicle would experience if there were no other vehicles or control devices at the intersection.

The average control delays for the various signalized study intersections were calculated using the Traffix analysis software. This software is consistent with the methodologies prescribed in the 2000 Edition of the HCM and correlates the average delay to the appropriate level of service designations (ratings). Table 2 summarizes the relationship between the delay and LOS for signalized intersections.

3. Unsignalized Intersections

For unsignalized intersections (including both all-way stop-controlled and side street stop-controlled), the Transportation Research Board's *2000 Highway Capacity Manual* methodology for unsignalized intersections was utilized. With this methodology, operations are defined by the average control delay per vehicle (measured in seconds) for each stop-controlled movement. The method incorporates delay associated with deceleration, acceleration, stopping, and moving up in the queue. For side street stop-controlled intersections, delay is typically represented for each movement from the minor (stop-controlled) approaches only. Table 3 summarizes the relationship between delay and LOS for unsignalized intersections.

Table 2 Signalized Intersection Level of Service Definitions		
Level of Service	Signalized Intersection	Average Control Delay (sec / veh)
A	Insignificant Delays: No approach phase is fully utilized and no vehicle waits longer than one red indications.	≤ 10
B	Minimal Delays: An occasional approach phase is fully utilized. Drivers begin to feel restricted.	> 10 – 20
C	Acceptable Delays: Major approach phase may become fully utilized. Most drivers feel somewhat restricted.	> 20 – 35
D	Tolerable Delays: Drivers may wait through no more than one red indication. Queues may develop but dissipate rapidly, without excessive delays.	> 35 – 55
E	Significant Delays: Volumes approaching capacity. Vehicles may wait through several signal cycles and long vehicle queues from upstream.	> 55 – 80
F	Excessive Delays: Represents conditions at capacity, with extremely long delays. Queues may block upstream intersections.	> 80

Source: *Highway Capacity Manual*, Transportation Research Board, 2000.

Table 3 Unsignalized Intersection Level of Service Definitions		
Level of Service	Unsignalized Intersection	Average Control Delay (sec / veh)
A	No delay for stop-controlled approaches.	0 - 10
B	Operations with minor delay.	> 10 – 15
C	Operations with moderate delays.	> 15 – 25
D	Operations with some delays.	>25 - 35
E	Operations with high delays, and long queues.	> 35 – 50
F	Operation with extreme congestion, with very high delays and long queues unacceptable to most drivers.	> 50

Source: *Highway Capacity Manual*, Transportation Research Board, 2000.

4. Significance Criteria

Based on the City of Alameda's standard thresholds of significance, a significant traffic-related impact would occur if the addition of new traffic as a result of a project would result in intersection operations deteriorating from an acceptable level (LOS D or better) to an unacceptable level (LOS E or worse).

II. EXISTING CONDITIONS

The following chapter provides a description of the existing transportation conditions for the study area and the existing intersection operations for the six Alameda Point study intersections analyzed in this report. Appendix B includes existing conditions data for the 31 intersections analyzed as part of the *Alameda Point Travel Demand Forecasting Report* (Fehr & Peers, 2003).

A. Study Area

Alameda Point is located at the west end of the island of Alameda (see Figure 1). The island's street grid provides local access. All regional access to Alameda and Alameda Point is provided via local roadways in Alameda and the City of Oakland. Regional access to and from Alameda Point is available at Interstate 880 (I-880) and Interstate 980 (I-980) via Oakland city streets. I-880 provides access to the south and to the north, with connections to Interstate 80 (I-80) and San Francisco via the Bay Bridge. I-980 provides access to the northeast, connecting with Interstate 580 (I-580) and State Route 24 (SR 24).

The primary regional access between Alameda Point and I-880/I-980 is State Route 260 (SR 260), which includes the inbound Webster and outbound Posey Tubes. The Webster and Posey Tubes connect the City of Alameda with the City of Oakland. The Webster Tube is two lanes in the south-bound direction from Oakland to Alameda, while the Posey Tube provides two lanes in the north-bound direction, from Alameda to Oakland. Access between Alameda and the freeways, through the Tubes, is available by traveling on local streets in downtown Oakland. Both the cities of Alameda and Oakland are constructed as grids, with east-west and north-south roadways traversing the cities (see Figure 3).

Important roadways within the study area include:

- *Webster Street and Constitution Way* – Traffic entering Alameda via the Webster Tube is routed onto either Webster Street or Constitution Way. These roadways are also used to depart Alameda by entering the Posey Tube. Webster Street is a four-lane major street with left turn pockets provided; it terminates at Central Avenue. Constitution Way is also a four-lane major street with turn pockets until it reaches Lincoln Avenue where it terminates at the Lincoln Avenue/Eighth Street intersection. South of Lincoln Avenue, Eighth Street connects Constitution Way to Central Avenue. Signals are located at major streets that cross these roadways, such as Atlantic Avenue, Lincoln Avenue, Santa Clara Avenue and Central Avenue.
- *Atlantic Avenue* – This is a major east-west street that serves as the primary access into and out of Alameda Point. The roadway provides two travel lanes in each direction west of Constitution Way and one travel lane in each direction between east of Constitution Way, where it becomes Sherman Street. Left turn pockets are provided at major intersections along its entire length.
- *Main Street* – The primary access and frontage road to Alameda Point is Main Street, which intersects with Atlantic Avenue at the eastern end of the Alameda Point area. Main Street has four travel lanes with no exclusive left-turn lanes. Signals are provided at Main Street/Atlantic Avenue, Main Street/West Midway Avenue, Main/Singleton (Coast Guard Housing), Main/Ferry Terminal, and Main Street/Pacific Avenue, also known as Main Street/Central Avenue.
- *Pacific Avenue/Lincoln Avenue* – This four-lane major roadway provides access to other portions of east Alameda. It is named Pacific Avenue between Main Street and 4th Street; east of 4th Street, Pacific Avenue splits, with its southerly branch becoming Marshall Way, which then becomes Lincoln Avenue at 5th Street. Lincoln Avenue continues east as a four-lane collector until it terminates at High Street. At Park Street, Lincoln Avenue intersects with Tilden Way, providing direct access to the Fruitvale (Miller/Sweeney) Bridge.
- *Central Avenue* – This primary east-west major street is designated as State Route 61 between Webster Street and Sherman Street and continues as a two-lane major street east of Sherman Street. SR 61 continues as a four-lane roadway east of Sherman Street on Encinal Avenue.

Five streets enter and exit Alameda Point: Main Street, Midway Avenue, Atlantic Avenue, Pacific Avenue, and West Oriskany Avenue. Each of these access routes or roadways is one lane in each direction except for Atlantic Avenue, which has two lanes in each direction.

Within the site, West Red Line Avenue, West Midway Avenue, West Tower Avenue, and Atlantic Avenue are east-west streets that link the former airfield and light industrial areas to the central core and residential areas. Lexington Street, Saratoga Street, Pan Am Way, and Orion Street provide north-south access from the pier facilities along the southern side of the site to the central portion of the site. Main Street also provides both east-west access and north-south access for Alameda Point.

There are no signalized intersections within Alameda Point; most of the intersections are stop sign controlled on the minor street approaches. The only signalized intersections are adjacent to Alameda Point on Main Street at West Midway Avenue, Atlantic Avenue, Pacific Avenue, Singleton Avenue and Ferry Terminal access road. The current Alameda Point street system is shown in Figure 3.

On the Oakland side, major north-south streets used or traveled by Alameda traffic include Broadway, Jackson Street, Webster Street, Harrison Street, Franklin Street, Madison Street and Oak Street. Generally, these streets (except Broadway and Jackson Street) are one-way streets. Major cross-streets are numbered and these also generally run in a one-way direction, such as 5th, 7th, 8th, 11th and 12th Streets. Traffic from western Alameda, including Alameda Point, contributes to traffic volumes on these streets, although the majority of Downtown Oakland traffic is locally-generated.

The Webster and Posey Tubes connect the City of Alameda with the City of Oakland. Access to the Webster Tube in Oakland occurs via two access points: southbound Webster Street at 7th Street and Broadway at 5th Street. Traffic exiting I-980 typically travels down Brush Street to 5th Street, and then left on 5th Street to Broadway. Traffic from I-880 southbound typically uses the Broadway/Alameda exit and from Adeline Street turns right onto 5th Street. Traffic exiting I-880 northbound exits at Broadway, turns right onto 7th Street, and then turns right again onto Webster Street.

Traffic leaving Alameda via the Posey Tube enters the City of Oakland at 7th and Harrison Streets. From this point, traffic accessing I-880 southbound is directed to travel eastbound on 7th Street to Madison Street, turning right on southbound Madison Street, then left on eastbound 5th Street to the freeway on-ramp south of Oak Street. Traffic accessing I-880 northbound travels eastbound on 7th Street, turns right onto Jackson Street, and then turns right onto the I-880 Jackson Street on-ramp. Traffic accessing I-980 northbound may follow the I-880 northbound path, or use Downtown Oakland streets to reach the on-ramp at 12th and Castro Streets.

B. Existing Traffic Counts

The traffic counts utilized to document existing conditions were gathered from several sources, including:

- City of Alameda comprehensive intersection traffic count survey conducted in the fall of 2000, which was supplemented in 2002 with 15 additional intersections;
- AM and PM peak hour traffic counts at select Alameda and Oakland intersections conducted by Fehr & Peers in May 2001;

Figure 4 displays the traffic control (stop signs or traffic signals), lane configurations and peak-hour traffic volumes for the six study intersections.

C. Intersection Levels of Service

Levels of service (LOS) were calculated at each study intersection during both the AM and PM peak hours. Table 3 lists the resulting LOS and corresponding delay at each study intersection. Levels of service in bold represent unacceptable (LOS E or F) operating conditions.

As shown in Table 4, all study intersections currently operate acceptably during both peak hours, therefore meeting the City of Alameda's level of service threshold (LOS D). One of the five existing study intersections currently operates at LOS D during both peak hours (Atlantic Avenue/Webster Street).

Table 4 Intersection Levels of Service Existing Conditions				
No.	Intersection	Traffic Control	LOS / Delay (Sec. / Veh.)	
			AM Peak Hour	PM Peak Hour
1	Atlantic Avenue / Main Street	Traffic Signal ¹	B (12.2)	C (20.9)
2	Atlantic Avenue / Poggi Street	Traffic Signal	A (6.2)	A (7.3)
3	Atlantic Avenue / Webster Street	Traffic Signal	D (35.1)	D (44.5)
4	Main Street / Pacific Avenue	Traffic Signal	A (7.4)	B (10.3)
5	Main Street / West Midway Avenue / Tinker Avenue	Side-Street Stop-Controlled	C (16.5)	B (14.1)
Notes: ¹ Signalized intersection LOS based on average intersection delay, based on the methodology in the <i>Highway Capacity Manual</i> , 2000 Edition. Source: Fehr & Peers, June 2003.				

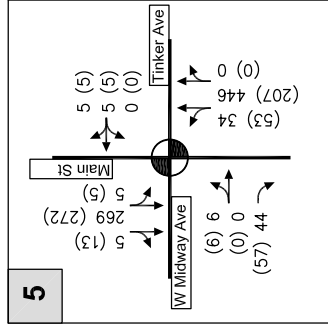
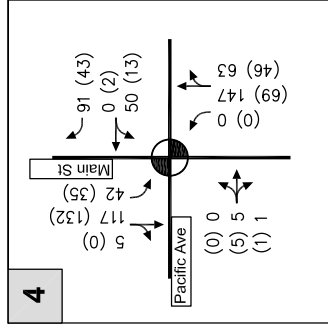
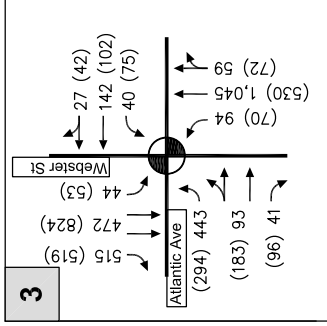
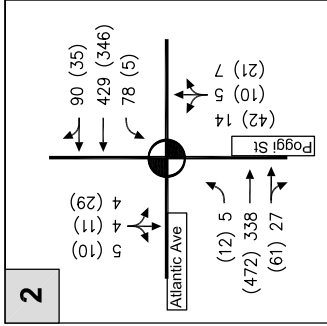
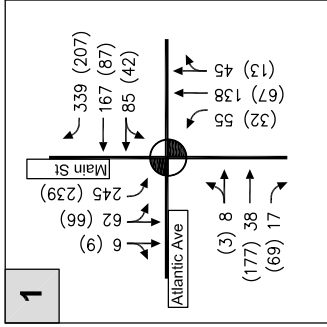

Not to scale

LEGEND:

XX (YY) = AM (PM) Peak Hour Traffic Volumes

= Traffic Signal

Alameda Land Use Planning
**EXISTING CONDITIONS
PEAK HOUR TRAFFIC VOLUMES
FIGURE 4**

III. TRANSPORTATION ANALYSIS

This chapter describes potential transportation impacts associated with the proposed redevelopment of Alameda Point at buildout in 2025 assuming cumulative growth in Alameda and planned transportation improvements by the year 2025. The Preliminary Development Concept provides a three-phase development program for Alameda Point. The program is designed to create a financially feasible development that corresponds with the environmental remediation program and that is consistent with the community's stated goals for Alameda Point. Given the complexity of the environmental remediation program, it is anticipated that Phase I will be developed between 2007 and 2011, Phase II between 2012 and 2017, and Phase III between 2018 and 2023. It should be noted that the phasing plan may change based upon possible changes to the Navy's remediation plans, the final Navy conveyance strategy, or changing market conditions.

Specifically the following is addressed:

- Trip estimates for Alameda Point including trip generation, internal capture rates, TDM reductions, and net new external trips for Phase I and full buildout
- Trip forecasts on key roadways: Webster and Posey Tubes, Atlantic Avenue, Tinker Avenue, Mitchell-Mosley Avenue for Phase I and full buildout
- Cumulative volumes with and without trips generated by Alameda Point and Level of Service at the six study intersections for full buildout only. Intersection Level of Service analysis was critical for full buildout in order to analyze some of the proposed intersection configurations, presented in the final chapter of this report. The intersection configurations highlight some critical trade-offs necessary to accommodate traffic, transit, bicyclists, and pedestrians.

This chapter also describes the methodology used to develop future traffic volumes and presents the corresponding level of service calculations for each study intersection.

The Preliminary Development Concept is outlined in the table below by phase:

Land Use	Development Program by Phase			
	I	II	III	Total
New Housing Units	1,148	241	346	1,735
Existing Housing Units	200	0	0	200
Community / Civic / Institutional (sq. ft.)	107,000	0	25,000	132,000
Office / R&D (sq. ft.)	512,000	1,562,000	855,000	2,929,000
Town Center Retail (sq. ft.)	275,000	61,000	0	336,000

Notes:

(1) Distribution and phasing of retail development will require further analysis and is subject to change.

A. Proposed Roadway Network

Several planned and programmed transportation improvements have been assumed as part of this traffic analysis. The assumed roadway improvements within the vicinity of the study are highlighted in Figure 5.

Roadway improvements are planned to be constructed in the vicinity of Alameda Point, and will result in additional east-west streets that will connect Alameda Point with the remainder of the island. All three are assumed to be in place by 2025. These improvements include the following:

- *Tinker Avenue Extension.* This roadway project will provide a new entry point into Alameda Point. The new Tinker Avenue extension will have a signalized intersection at Webster Street, from which a two-way four-lane facility will provide access to Main Street and Alameda Point. In the interim, a two-lane facility from Main Street to 5th Street will be provided.
- *The Mitchell/Mosley Connector.* This roadway will also provide a new entry point into Alameda Point. This facility will link two two-lane roadways, enabling a continuous flow from the Marina Village area to Alameda Point. This facility will be completed with local development funding.

Other roadway improvements also assumed in Alameda include:

- *Fifth Street Extension.* This proposed north-south roadway will consist of four lanes and will be located east of the Webster-Posey Tubes. This roadway will provide additional access to the Marina Village area from Alameda Point. Fifth Street would extend from Atlantic Avenue to the south, through Tinker Avenue and terminate at Mitchell-Mosley Avenue to the north. Traffic signals would be installed at all three intersections.
- *College Driveway / Webster Street Intersection.* This signalized T-intersection will provide direct access to the College of Alameda from Webster Street. Webster Street is currently a four-lane roadway. The new intersection will provide right-in/right-out access.

The construction of the proposed improvements in Alameda would result in 10 new signalized intersections. Based on consultation with City staff, one of those intersections, Main Street/Mitchell-Mosley Avenue has been selected for analysis under buildout (2025) conditions in addition to the five existing study intersections, shown in Figure 6.

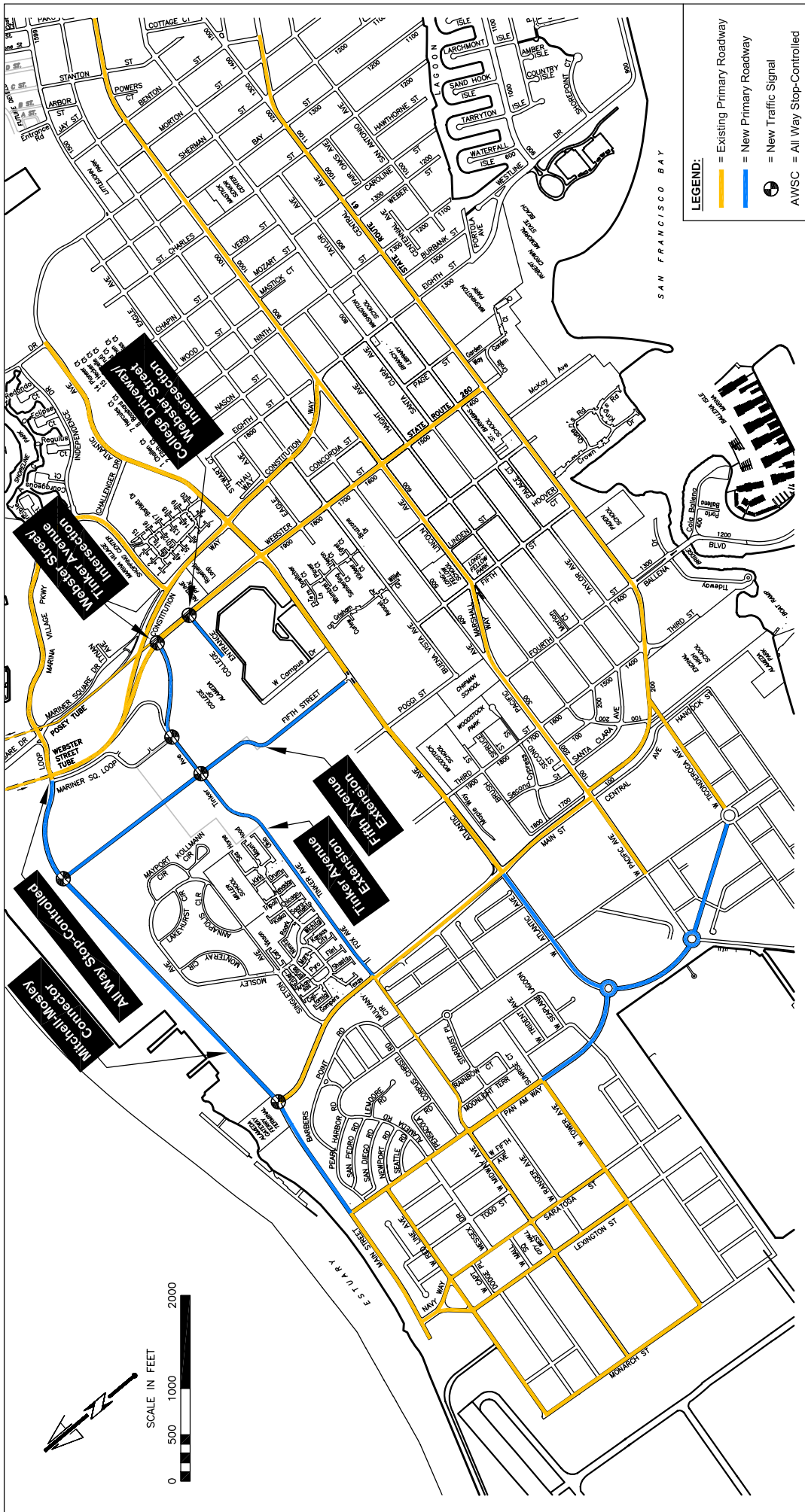

Alameda Land Use Planning

PROPOSED ROADWAY NETWORK
FIGURE 5

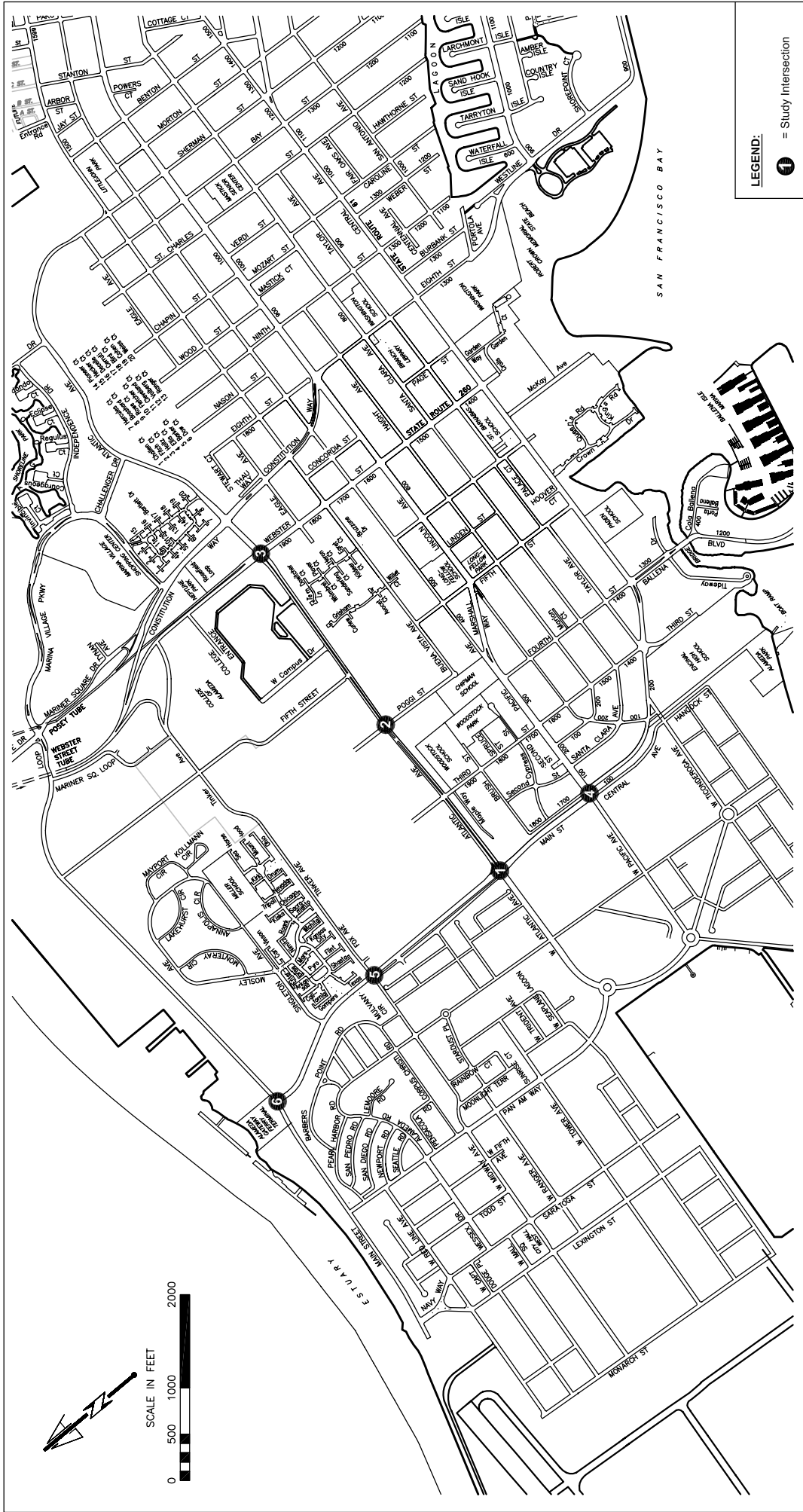

Alameda Land Use Planning

PROPOSED ROADWAY STUDY INTERSECTIONS
FIGURE 6

B. Cumulative (Year 2025) Land Use Assumptions

The number of jobs assumed in 2025 for the purposes of this report was 49,779. This is a conservative assumption as the Association of Bay Area Governments current *Projections 2005* series assumes 44,680 jobs in Alameda in 2025. When the project Environmental Impact Report is prepared, the 2025 job projections should be further refined to reflect the most current projections.

C. Traffic Estimates

The amount and effects of new traffic associated with the proposed redevelopment of Alameda Point was estimated using a three-step process: (1) trip generation; (2) trip distribution, and (3) trip assignment. In the first step, the amount of new traffic generated by Alameda Point, entering and exiting Alameda Point, is estimated on a daily and peak-hour basis. In the second step, the general directions that new traffic would approach and depart the site are estimated. In the third step, trips are assigned to specific streets and routes along the roadway network to reach their intended destination. The results of this three-step process are described in the following sections.

1. Trip Generation

The amount of traffic that would be generated by the development at Alameda Point was estimated based on the data presented in the Institute of Transportation Engineers' (ITE) *Trip Generation* (7th Edition, 2003) for the following land uses:

- General Office Building
- Residential
- Warehousing
- Manufacturing
- Research and Development Center

The AM and PM peak hour trips rates for the specialty retail component of the proposed development at Alameda Point are based on San Diego Association of Government's (SANDAG) traffic data and trip rates.

The total Phase I trip generation for Alameda Point is presented in the table below. As shown, Alameda Point would generate 1,650 trips (811 inbound and 840 outbound) in the AM peak hour and 2,456 trips (1,220 inbound and 1,236 outbound) in the PM peak hour. The residential component of the Preliminary Development Concept (PDC) would generate the majority of the traffic with approximately 50 percent of the total trips in the AM peak hour and 45 percent in the PM peak hour.

Table 6 Phase I Trip Generation							
Land Use	Size (dwelling units, ksf)	Total Trip Generation					
		AM Peak Hour			PM Peak Hour		
		Total	In	Out	Total	In	Out
Residential ¹	1,365	832	188	643	1,074	687	387
Employment ²	512	521	444	78	492	88	404
Specialty Retail ³	275	297	178	119	891	446	446
TOTAL		1,650	811	840	2,456	1,220	1,236
Notes: ¹ Residential development includes Multi-Unit Affordable housing, Affordable Duplexes, and Single-Family Detached housing with 217 second or "in-law" units. ² Employment category includes Office, Warehousing, Manufacturing, and Research & Development uses. ³ San Diego Association of Governments (SANDAG), Trip Generation Manual, May 2003 Source: Institute of Transportation Engineers, SANDAG, and Fehr & Peers, August 2005.							

Given that Alameda Point would have the site characteristics of a multi-use development, this study anticipates that internal trip-making between the residential, employment, and retail uses would occur. A key characteristic of a multi-use development is that trips among the various land uses can be made on site and these internal trips are not made on the external street system, but on internal pathways or roadways. A high proportion of these internal trips would be made by either walking or bicycling.

Consistent with the Alameda County Congestion Management Agency's Alameda countywide model, this study utilized an average PM peak hour internal capture rate of 14 percent. No internalization was assumed for the AM peak period. This rate was derived from the transportation demand model the City of Alameda used when creating the Alameda Point General Plan Amendment. The peak hour internal capture rate is a percent reduction applied to the trip generation estimates for individual land uses to account for trips internal to the site. A high proportion of these internal trips would be made by either walking or bicycling. When the EIR comes forward, the internalization will be refined for the specific project description, which may result in the internalization rising or falling based on the final mix of uses.

In addition to the internalization that is expected to occur within Alameda Point, this analysis also assumes a reduction for Transportation Demand Management (TDM) measures. TDM is a set of strategies, measures, and incentives to encourage people to walk, bicycle, use public transportation, carpool, or use other alternatives to driving alone. TDM measures produce more mobility on the existing transportation systems, boost economic efficiency of the current transportation infrastructure, improve air quality, save energy, and reduce traffic congestion. The development plan for Alameda Point includes aggressive TDM measures vehicle trips that are outlined in the *Alameda Point Transportation Strategy Report* (Fehr & Peers, 2005). Per the City's approved Traffic Capacity Management Procedures (TCMP) adopted by the City Council in 2001, development west of Grand Street should propose feasible TSM/TDM measures to reduce the standard peak hour trips generated by at least 10% for residential development and 30% for non-residential development. These

reductions are goals that the project will strive to meet using an aggressive TDM plan and transit strategy. This report presents the full range of possible outcomes, including the number of trips generated if the TDM and transit strategies have no effect and the number generated if the project meets its goals. Depending on the final mix of uses at Alameda Point and the final design and scope of both the transit and TDM plans, the actual number of trips generated by the project will likely be somewhere within the range shown. The final EIR will evaluate a conservative number. Table 7 shows the resulting new trips external to Alameda Point after taking the reductions for internal trips and TDM measures.

Table 7 Phase I Net New External Trips							
Land Use	Size (dwelling units, ksf)	AM Peak Hour			PM Peak Hour		
		Total	In	Out	Total	In	Out
Residential ¹	1,365	748	170	579	827	514	313
Employment ²	512	365	311	54	305	51	254
Specialty Retail ³	275	297	178	119	771	370	401
NET NEW TRIPS w/TDM & INTERNALIZATION		1,410	659	752	1,904	935	969
TOTAL RAW TRIPS		1,650	811	840	2,456	1,220	1,236
Net Reduction in Trips		-240	-152	-88	-553	-285	-267
Notes: ¹ Residential development includes Multi-Unit Replacement housing, Affordable Duplexes, and Single-Family Detached housing. ² Employment category includes Office, Warehousing, Manufacturing, and Research & Development uses. ³ San Diego Association of Governments (SANDAG), Trip Generation Manual, May 2003 Source: Institute of Transportation Engineers and Fehr & Peers, August 2005.							

The total trip generation for Alameda Point is presented in Table 8. As shown, Alameda Point would generate 4,599 trips (3,038 inbound and 1,561 outbound) in the AM peak hour and 5,521 trips (2,085 inbound and 3,436 outbound) in the PM peak hour. The employment component of the proposed development would generate the majority of the traffic with approximately 58 percent of the total trips in the AM peak hour and 44 percent in the PM peak hour.

Table 8 Trip Generation for Full Buildout							
Land Use	Size (dwelling units, ksf)	Total Trip Generation					
		AM Peak Hour			PM Peak Hour		
		Total	In	Out	Total	In	Out
Residential ¹	2,059	1,257	285	972	1,624	1,039	585
Employment ²	2,929	2,979	2,535	444	2,809	503	2,306
Specialty Retail ³	336	363	218	145	1,089	544	544
TOTAL		4,599	3,038	1,561	5,521	2,085	3,436
Notes: ¹ Residential development includes Multi-Unit Affordable housing, Affordable Duplexes, and Single-Family Detached housing with 324 second or "in-law" units ² Employment category includes Office, Warehousing, Manufacturing, and Research & Development uses. ³ San Diego Association of Governments (SANDAG), Trip Generation Manual, May 2003 Source: Institute of Transportation Engineers, SANDAG, and Fehr & Peers, August 2005.							

Based on the internal capture rates presented in Table 6 and the TDM reductions described above, the resulting net new trips external to Alameda Point is displayed in Table 9.

Table 9 Net New External Trips							
Land Use	Size (dwelling units, ksf)	AM Peak Hour			PM Peak Hour		
		Total	In	Out	Total	In	Out
Residential ¹	2,059	1,132	257	875	1,240	777	463
Employment ²	2,929	2,085	1,775	310	1,713	292	1,421
Specialty Retail ³	336	363	218	145	931	452	479
NET NEW TRIPS w/TDM & INTERNALIZATION		3,580	2,249	1,331	3,884	1,521	2,363
TOTAL RAW TRIPS		4,599	3,038	1,561	5,521	2,085	3,436
Net Reduction in Trips		-1,019	-789	-230	-1,637	-564	-1,073
Notes: ¹ Residential development includes Multi-Unit Replacement housing, Affordable Duplexes, and Single-Family Detached housing. ² Employment category includes Office, Warehousing, Manufacturing, and Research & Development uses. ³ San Diego Association of Governments (SANDAG), Trip Generation Manual, May 2003 Source: Institute of Transportation Engineers and Fehr & Peers, June 2003.							

2. Trip Distribution and Assignment

The trip distribution pattern for the proposed development was estimated based on the trip distribution process used in the Alameda County Congestion Management Agency's Alameda countywide model³, which estimates the direction of travel for each trip that is produced and attracted by the trip generation estimates. Figures 6 through 8 present the AM and PM peak hour trip distributions by land use for trips entering and exiting Alameda Point from three directions: (1) East Alameda, (2) South-Central Alameda, and (3) Oakland.

As shown on Figure 7, the majority of retail traffic into Alameda Point is expected to come from the east with 62 percent during the AM peak hour and 58 percent during the PM peak hour. Another 25 percent of the AM peak hour and 26 percent of the PM peak hour traffic is expected to come from Oakland via the Webster tunnel. The remaining 13 percent of AM peak hour and 16 percent of PM peak hour traffic will come from the south-central Alameda. Similar calculations were done to obtain the trip distribution patterns for retail traffic exiting Alameda Point. Due to the retail's high capture rate from the island, very few trips are expected to utilize the Webster and Posey tubes.

Figures 8 and 9 present the estimated trip distributions for the office and residential components of Alameda Point. Approximately one-half of residential and one-half of employment trips are expected to travel through the tubes during the peak hours.

³ The horizon year for the model is 2020 as are the employment projections. A 2.5% growth factor was added to all traffic outputs to estimate traffic for 2025. As part of the subsequent EIR, the model will be re-run with the final land use designations for Alameda Point and the appropriate horizon year.

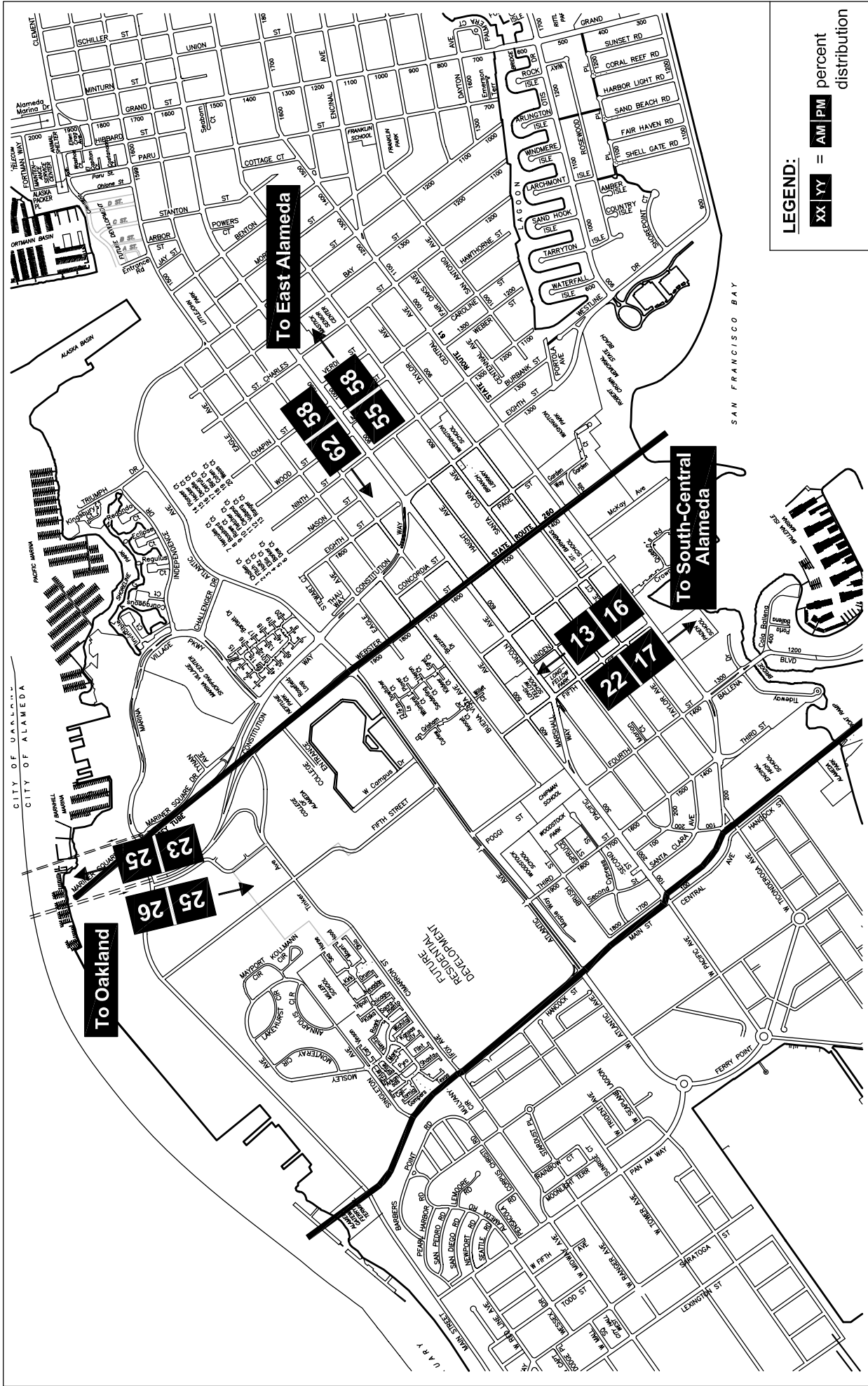

Alameda Land Use Planning
TRIP DISTRIBUTION (RETAIL)
FIGURE 7

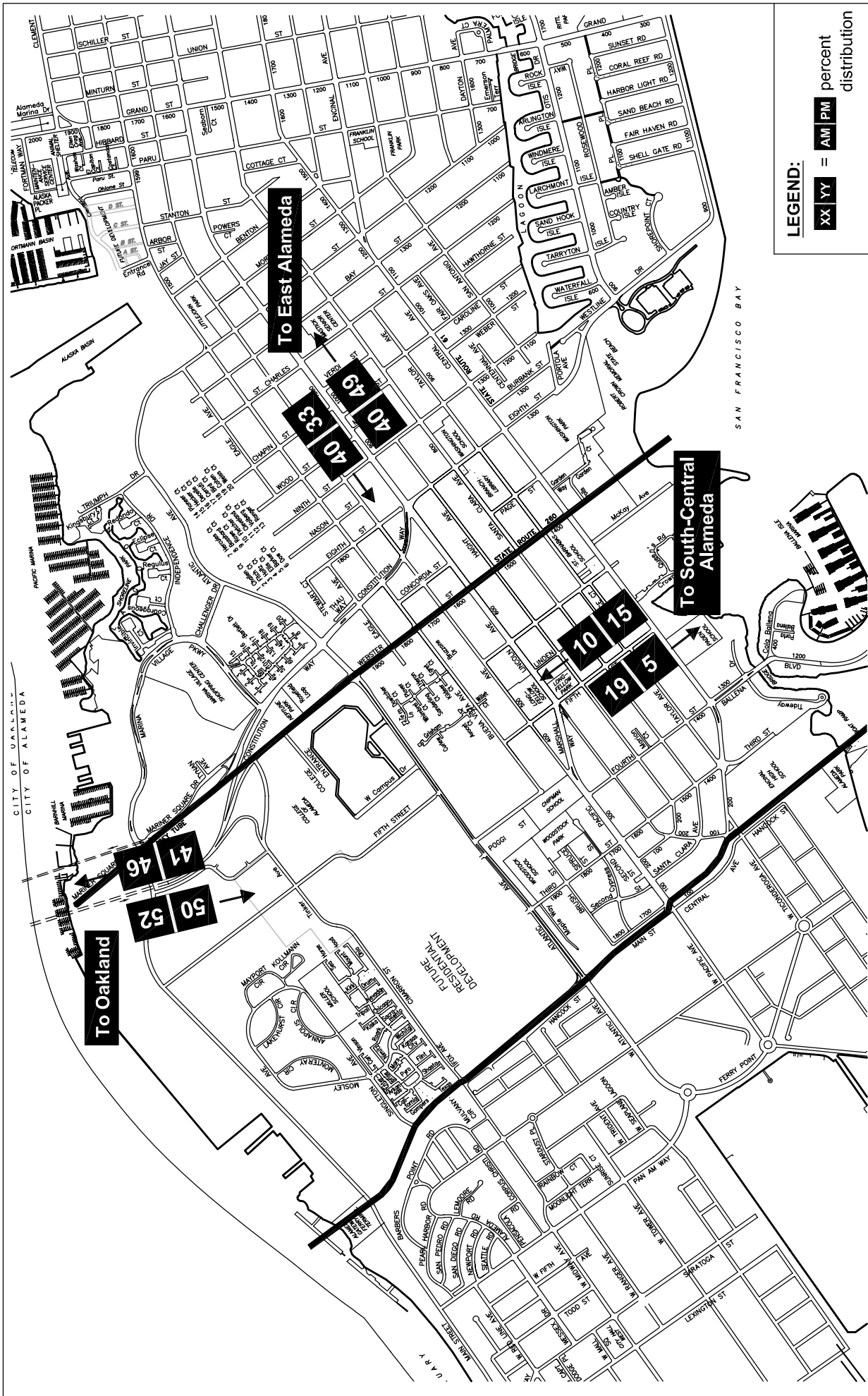

LEGEND:
 XX YY = AM PM percent distribution

Alameda Land Use Planning
TRIP DISTRIBUTION (OFFICE)
FIGURE 8

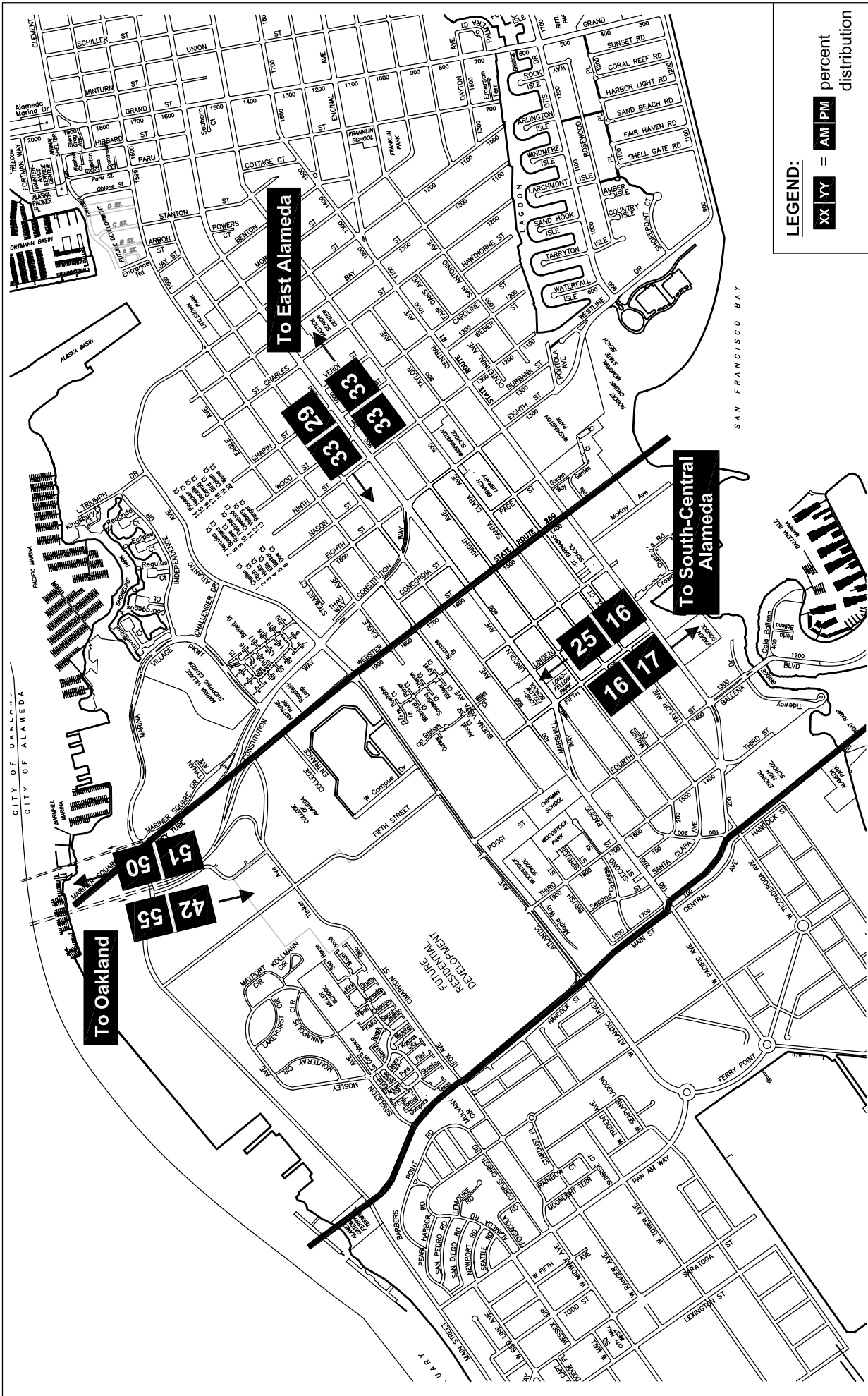

Alameda Land Use Planning
**TRIP DISTRIBUTION
 (RESIDENTIAL)**
FIGURE 9

Table 10 presents projected Phase I (2010) traffic volumes for key Alameda Point access roadways in the AM and PM Peak periods. These volumes were taken from the location with the highest volumes along the roadway within the study area.

Table 10 Alameda Point Phase I Vehicle Trips on Select Roadways			
Roadway	Direction	Alameda Point Trips AM Peak	Alameda Point Trips PM Peak
Webster Tube	Southbound	271	405
Posey Tube	Northbound	345	374
Atlantic Avenue ¹	Eastbound	290	321
	Westbound	236	305
Tinker Avenue ²	Eastbound	239	288
	Westbound	169	253
Mitchell-Mosley Avenue ³	Eastbound	45	76
	Westbound	42	73
Notes: ¹ West of Webster Street ² East of Main Street ³ East of Marine Square Source: Fehr & Peers, August 2005.			

3. Buildout Traffic Volumes

Future traffic volumes were derived by estimating the traffic growth between the 2025 traffic projections to Year 2000 traffic projections from the Alameda County Congestion Management Agency's Alameda countywide model. The estimated growth in traffic was then added to existing traffic counts to develop cumulative baseline traffic volumes. Traffic was then added onto the cumulative 2025 traffic volumes to develop the forecasts for cumulative growth plus the development at Alameda Point. Figure 11 shows the new roadway geometry, including number of lanes, and Figure 12 illustrates the resulting AM and PM peak-hour traffic volumes for cumulative plus buildout (2025) conditions.

Table 11 presents the projected Buildout (2025) traffic volumes for key Alameda Point access roadways in the AM and PM peak hours. These volumes were taken from the locations with the highest volumes along the roadway within the study area.

Table 10 Alameda Point Vehicle Trips on Select Roadways (Buildout 2025)							
Roadway	Direction	Alameda Point Trips AM Peak	Alameda Point Trips PM Peak	Cumulative plus Alameda Point AM Peak	Cumulative plus Alameda Point PM Peak	Alameda Point Trips as % of Total AM Peak	Alameda Point Trips as % of Total PM Peak
Atlantic Avenue ¹	Eastbound	508	871	984	1244	52%	70%
	Westbound	922	529	1430	1263	64%	42%
Tinker Avenue ²	Eastbound	432	731	437	872	99%	84%
	Westbound	639	436	779	446	82%	98%
Mitchell-Mosley Avenue ³	Eastbound	78	152	438	700	18%	22%
	Westbound	110	108	347	257	32%	42%
Main Street ⁴	Northbound	166	617	1048	908	16%	68%
	Southbound	468	237	924	574	51%	41%
Webster Tube	Southbound	1050	697	--	--	--	--
Posey Tube	Northbound	607	1005	--	--	--	--
Notes: ¹ West of Webster Street ² East of Main Street ³ East of Marine Square Loop ⁴ South of Midway/Tinker Source: Fehr & Peers, August 2005.							

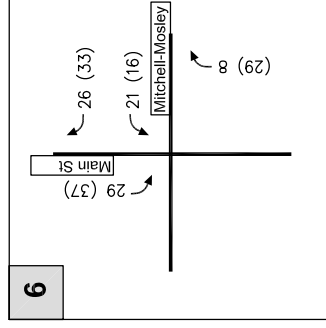
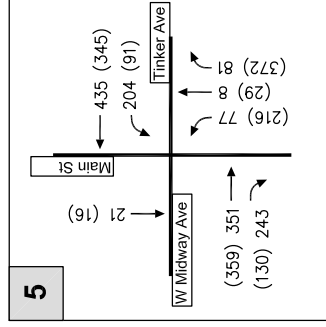
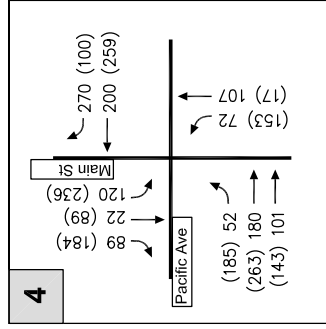
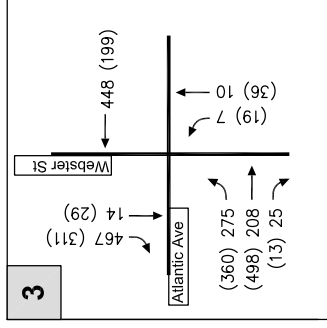
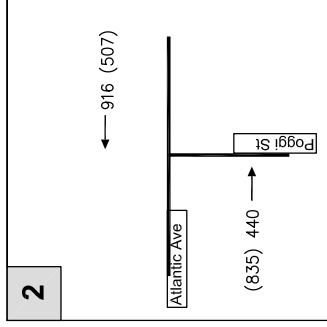
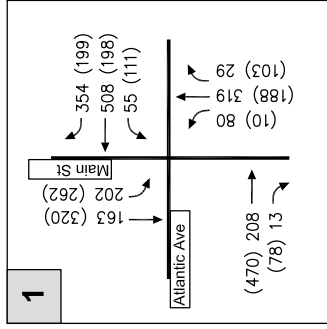

LEGEND:

XX (YY) = AM (PM) Peak Hour Traffic Volumes

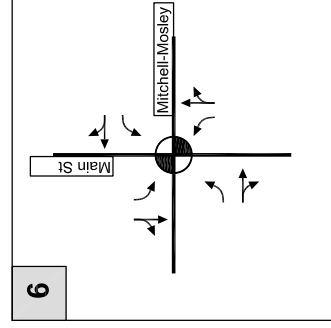
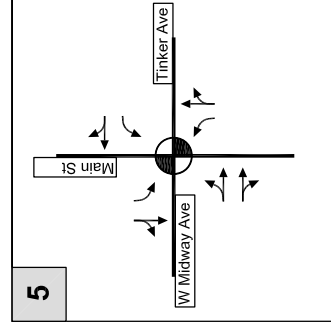
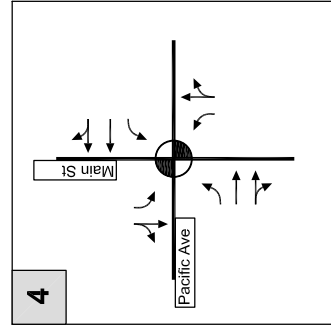
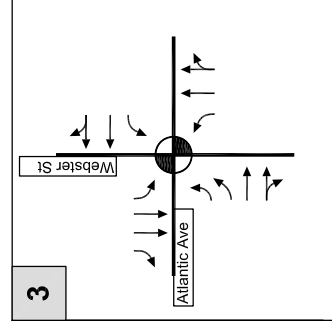
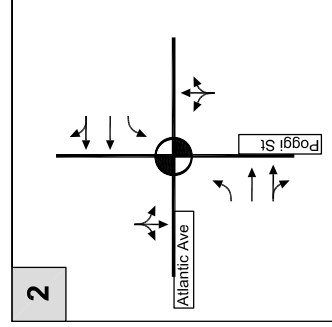
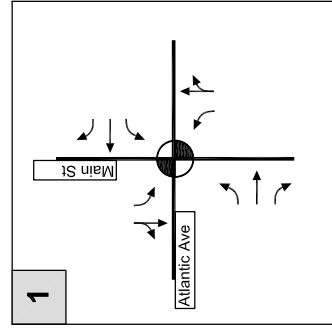

LEGEND:
 = Traffic Signal

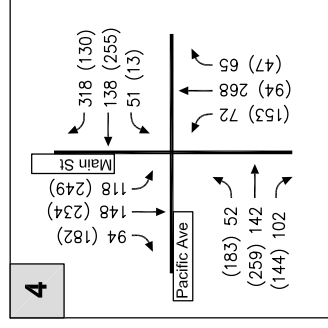
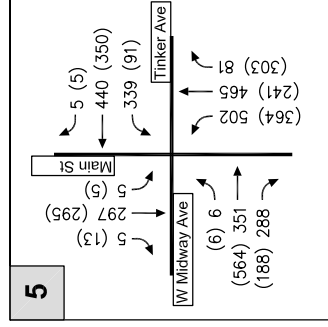
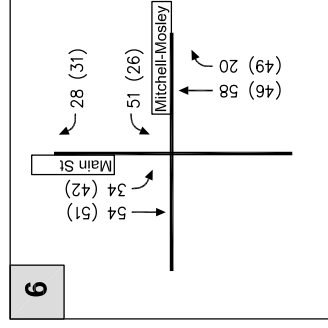
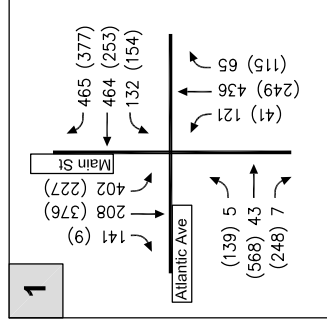
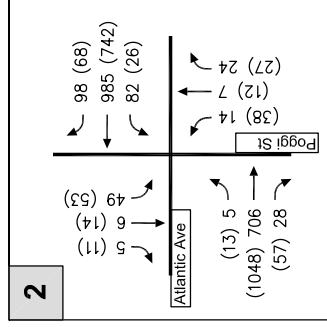
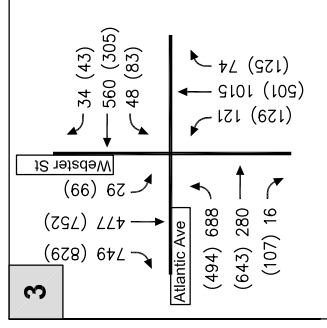

LEGEND:

XX (YY) = AM (PM) Peak Hour Traffic Volumes

Alameda Land Use Planning
CUMULATIVE PLUS PROJECT BUILDOUT (2025) CONDITIONS
PEAK HOUR TRAFFIC VOLUMES
FIGURE 12

D. Intersection Levels of Service

Table 11 compares the AM and PM peak hour LOS under the existing and cumulative plus Alameda Point development conditions.

The study intersections are expected to maintain current operations at LOS D or better under both peak hours with the exception of Atlantic Avenue/Webster Street, which will degrade to LOS E during both peak hours.

This study assumed that improvements to the Main Street/Tinker Avenue/Midway Avenue intersection would be included as part of the Tinker Avenue Extension project. Therefore, based on the projected traffic volumes at this intersection, this traffic analysis assumed the installation of a traffic signal as well as the following roadway improvements:

- Provide one additional through lane on eastbound Midway Avenue;
- Provide one exclusive left-turn lane on northbound and southbound Main Street
- Provide an exclusive left-turn lane for westbound Tinker Avenue.

With these assumptions, the Atlantic Avenue/Webster Street intersection would be the only study intersection to degrade to unacceptable, LOS E, operations during the PM peak hour in the Buildout 2025 scenario. All other study intersection would operate at acceptable levels in both the AM and PM peak hours.

Table 11 Intersection Levels of Service Cumulative (Year 2025) Plus New Traffic from Alameda Point						
No.	Intersection	Traffic Control	Existing (Delay: Sec. / Veh.)		Cumulative Plus New Traffic (Delay: Sec. / Veh.)	
			AM Peak Hour	PM Peak Hour	AM Peak Hour	PM Peak Hour
1	Atlantic Avenue / Main Street	Traffic Signal ¹	B (12.2)	C (20.9)	D (44.1)	D (35.8)
2	Atlantic Avenue / Poggi Street	Traffic Signal	A (6.2)	A (7.3)	A (7.4)	A (7.1)
3	Atlantic Avenue / Webster Street	Traffic Signal	D (35.1)	D (44.5)	E (59.0)	E (55.3)
4	Main Street / Pacific Avenue	Traffic Signal	A (7.4)	B (10.3)	B (18.7)	C (21.8)
5	Main Street / West Midway Avenue / Tinker Avenue	Traffic Signal	C (16.5)	B (14.1)	D (46.8)	D (36.4)
6	Main Street/Mitchell-Mosley Avenue	Traffic Signal	N/A	N/A	A (9.5)	A (7.4)

Notes:
¹ Signalized intersection LOS based on average intersection delay, based on the methodology in the *Highway Capacity Manual*, 2000 Edition.
 Source: Fehr & Peers, August 2005.

IV. CONCLUSIONS AND RECOMMENDATIONS

This chapter summarizes recommendations for key roadways and intersections. Findings of the travel demand forecast were that the Atlantic Avenue/Webster Avenue intersection would operate at unacceptable levels (LOS E) during both peak hours under the Buildout 2025 scenario. All other study intersections would operate at acceptable levels in both the AM and PM peak hours.

A. Recommended Street Layout

Main Street "Road Diet"

The proposed roadway network includes a redesigned Main Street where the existing four travel lanes (two lanes in each direction) are converted to three lanes (one lane in each direction and a center bi-directional left turn lane). This technique, commonly referred to as a "road diet", utilizes the reclaimed right-of-way to create a more multi-modal thoroughfare by installing either some or all of the following facilities: bicycle lanes, transit lanes, sidewalks, on-street parking, landscaped medians and roadside planter strips. Observed benefits include reduced vehicles speeds, reduced collisions and injuries, improved mobility and access, and improved livability and quality of life.

The proposed Main Street design includes bicycle lanes, on-street parking, landscaped roadside planters, and sidewalks as shown in Figure 13. These improvements, accomplished by the removal of one traffic lane in each direction, will not compromise the City of Alameda's intersection LOS standard. The proposed lane configuration changes were assumed in the Buildout 2025 scenario and all study intersections on Main Street were projected to operate at LOS D or better in the AM and PM peak hours.

The ultimate decision about the design of Main Street is more of a policy question than one of traffic operations. If the City chooses to create a three-lane street with bicycle lanes and on-street parking, Main Street will be a slower street that feels like a residential collector. This is consistent with the vision in the General Plan and Reuse Plan. Specifically, policies calling for roads with a 25 mile an hour design speed, lower speeds to reduce traffic noise and the need for soundwalls, and integration of Alameda Point into the rest of Alameda. However, the trade-off is that this roadway may experience higher levels of congestion, particularly during the peak hours.

This roadway design has benefits including lower vehicle speeds, fewer injuries and collisions, reduced conflict points, and improved sight distance.⁴ There are several streets in the Bay Area that have experienced a "four to three" conversion (from four lanes to two lanes and a left-turn lane). Examples include Marin Avenue in Berkeley/Albany, 14th Street in San Leandro, and High Street in Oakland. These roadways each experience volumes similar to the projected volumes for Main Street. Most notably, Marin Avenue carries over 25,000 vehicles per day.

Under either scenario, the City will retain the right-of-way that is currently available. If congestion becomes unbearable, the City will still have approximately 60 feet of roadway available. This is adequate for two lanes in each direction and a turn lane but would entail the removal of the bike lanes and on-street parking (no curb relocation would be necessary).

⁴ Rosales, Jennifer, P.E., *Applying the Road Diet for Livable Communities*, ITE International Meeting, August 2005

Figure 13 – Proposed Main Street Design

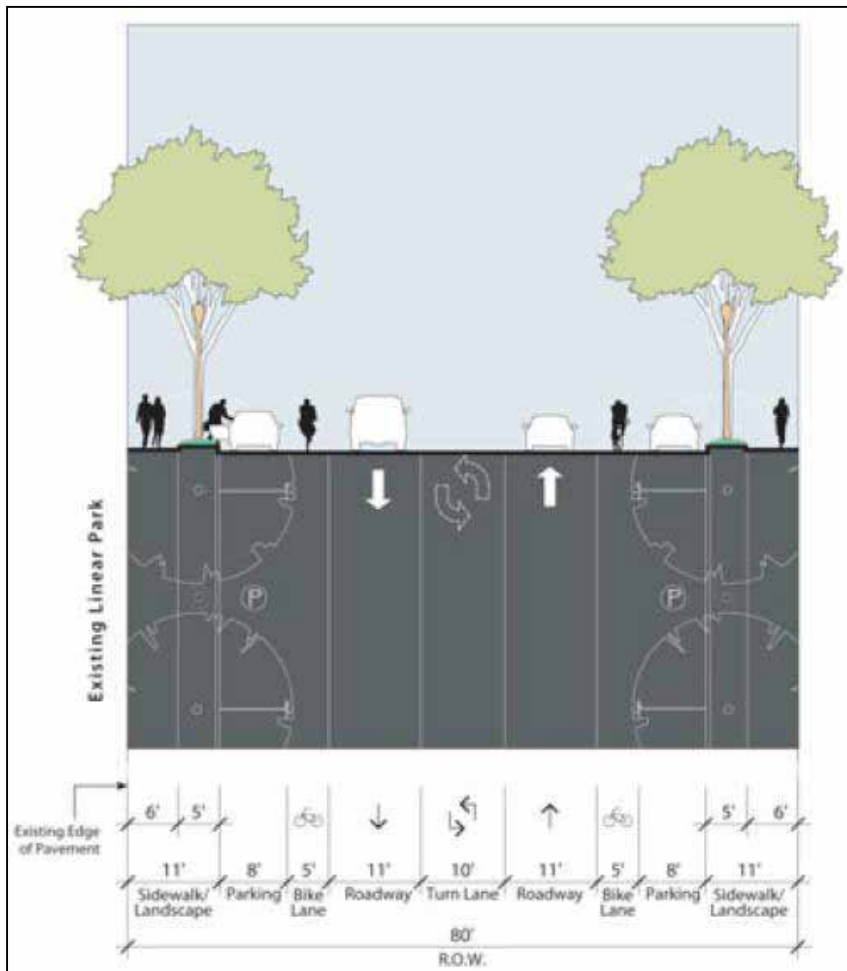

Source: Roma Design Group, 2005

B. Recommended Intersection Configurations

Atlantic Avenue/Webster Street

Located on the south side of the Webster Tube, the intersection of Atlantic Avenue/Webster Street has high vehicle volumes. The intersection operates at LOS D in existing conditions in both the AM and PM peak hours and is projected to degrade to LOS E in both peak hours under the buildout 2025 scenario. The intersection is adjacent to the College of Alameda and there are frequent pedestrian crossings at this location as people access nearby shopping centers and bus stops.

West of the intersection, on the south side of Atlantic Avenue there is an existing rail right-of-way (ROW), called the Beltline. As part of the redevelopment plan, there is a proposal to use the extra ROW on Atlantic to provide bus only lanes and either on-street bicycle facilities or a mixed use trail.

Bus only lanes running in the center of Atlantic Avenue would speed bus operations and provide the opportunity for a future conversion to Bus Rapid Transit or Light Rail.

Figure 14 shows a conceptual design for the proposed configuration of the Atlantic Avenue/Webster intersection. On the westbound approach, there would be a new westbound bus-only left-turn lane and a mixed use trail. Without the new bus-only lanes, this configuration is the same one recommended in the General Plan Amendment Environmental Impact Report.

The additional westbound turn lanes would shift the alignment of the westbound thru lanes to the south. Aligning the thru lanes with the receiving lanes on the east side would require the City of Alameda acquire right-of-way on the south-east corner of the intersection. This land is currently a parking lot for the adjacent shopping center. Additional design work would be necessary to identify the exact amount of land needed, but initial design suggests that the alignment thru the intersection would conform to Caltrans design standard for the maximum intersection off-set and the following curve would meet Caltrans minimum radius requirements for roadway with a 30 mile per hour design speed. The conceptual design work also confirms there is adequate space along Atlantic Avenue to accommodate two center bus-only lanes and associated five foot station platforms.

The City would like to improve pedestrian conditions at this intersection. Removing the southbound channelized right-turn lane may improve pedestrian safety. However, the existing right-turn volumes at this location are greater than 500 per PM peak hour, which suggests that this modification would cause significant increases to vehicle delay. Another goal for this intersection is to prioritize transit operations and after removing the southbound right-turn lane, a southbound transit-only lane may be warranted so that transit vehicles do not wait in the same congestion as other vehicles. The addition of the new transit-only lane cancels out the initial pedestrian benefits from the removal of the right-turn lane by the increase crossing distance caused by the new lane. For this reason, the conceptual design does not eliminate the southbound channelized right-turn lane.

The additional turn lanes are necessary to improve the level of service at this intersection. However, as noted above, they, along with the bus-only lanes, create a challenge for the City. The City may choose to accept a lower level of service for drivers at this location in order to keep a high level of transit service and shorten pedestrian crossing times. Alternately, the City may choose to eliminate the bus-only turn lanes in order to improve conditions for drivers and pedestrians.

Atlantic Avenue/Main Street

Figure 15 shows the proposed configuration of Atlantic Avenue/Main Street. Consistent with the recommended street layout, Main Street would have one left-turn lane and one shared thru/right lane. Additionally, there would be on-street bicycle lanes and parking. This document recommends a six foot bicycle lane and a seven foot parking lane, which is a more bicycle-friendly design. This is a design detail that should be explored when the project comes forward for review, but it does not need to be resolved as part of the planning process. Atlantic Avenue would have center eastbound and westbound bus-only lanes. There would be an impact to the existing parking lot at the corner of Atlantic Avenue/Main Street which serves the retail at that location.

Main Street/Midway Ave/Tinker Avenue

Figure 16 shows the proposed configuration of Main Street/Midway Avenue/Tinker Avenue. The Tinker Avenue (westbound) approach would be a new roadway with a left-turn lane and a shared thru/right turn lane. Midway Avenue would have a shared thru-left lane and a shared thru-right lane. Consistent with the recommended street layout, Main Street would have one left-turn lane and one shared thru/right lane on both approaches. All roadways would have on-street bicycle lanes and there would be on-street parking on Main Street.

Main Street/Mitchell-Mosley Avenue

The Main Street/Mitchell-Mosley Avenue intersection would be a new intersection on Main Street. Figure 17 shows the proposed configuration for this new signalized intersection. Consistent with the recommended street layout, Main Street would have one left-turn lane and one shared thru/right lane on both approaches. Mitchell-Mosley Avenue would also have one left-turn lane and one shared thru/right lane on both approaches. Both roadways would have on-street bicycle lanes and on-street parking. Similar to Atlantic Avenue/Main Street, this figure shows a wider recommended bicycle lane and a smaller parking lane to maximize the bicycle-friendliness of the street. When the project moves further into the design phase, this detail will be resolved.

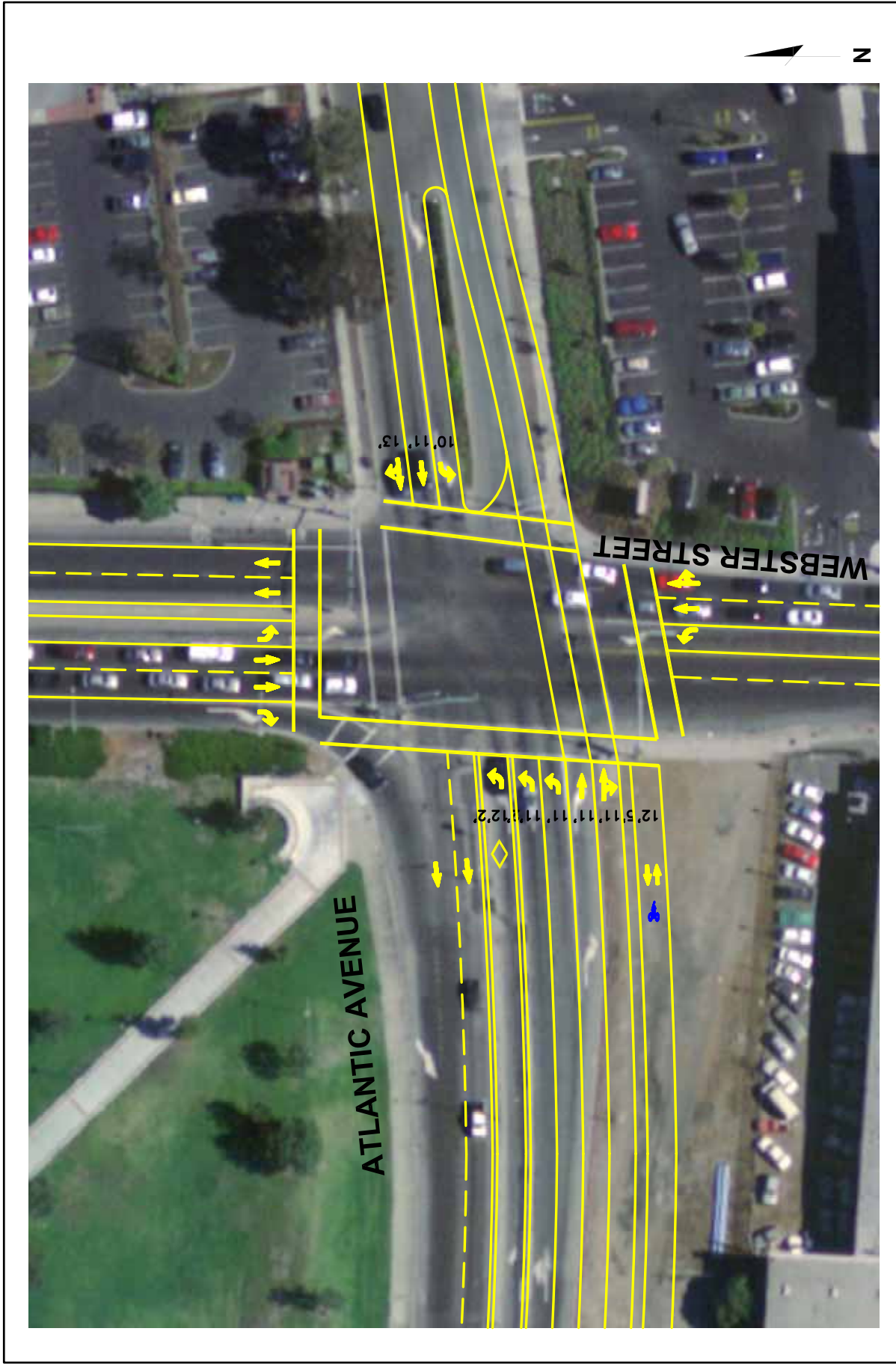

Alameda Land Use Planning
**PROPOSED CONCEPT DESIGN OF
 ATLANTIC AVENUE/WEBSTER STREET**
FIGURE 14

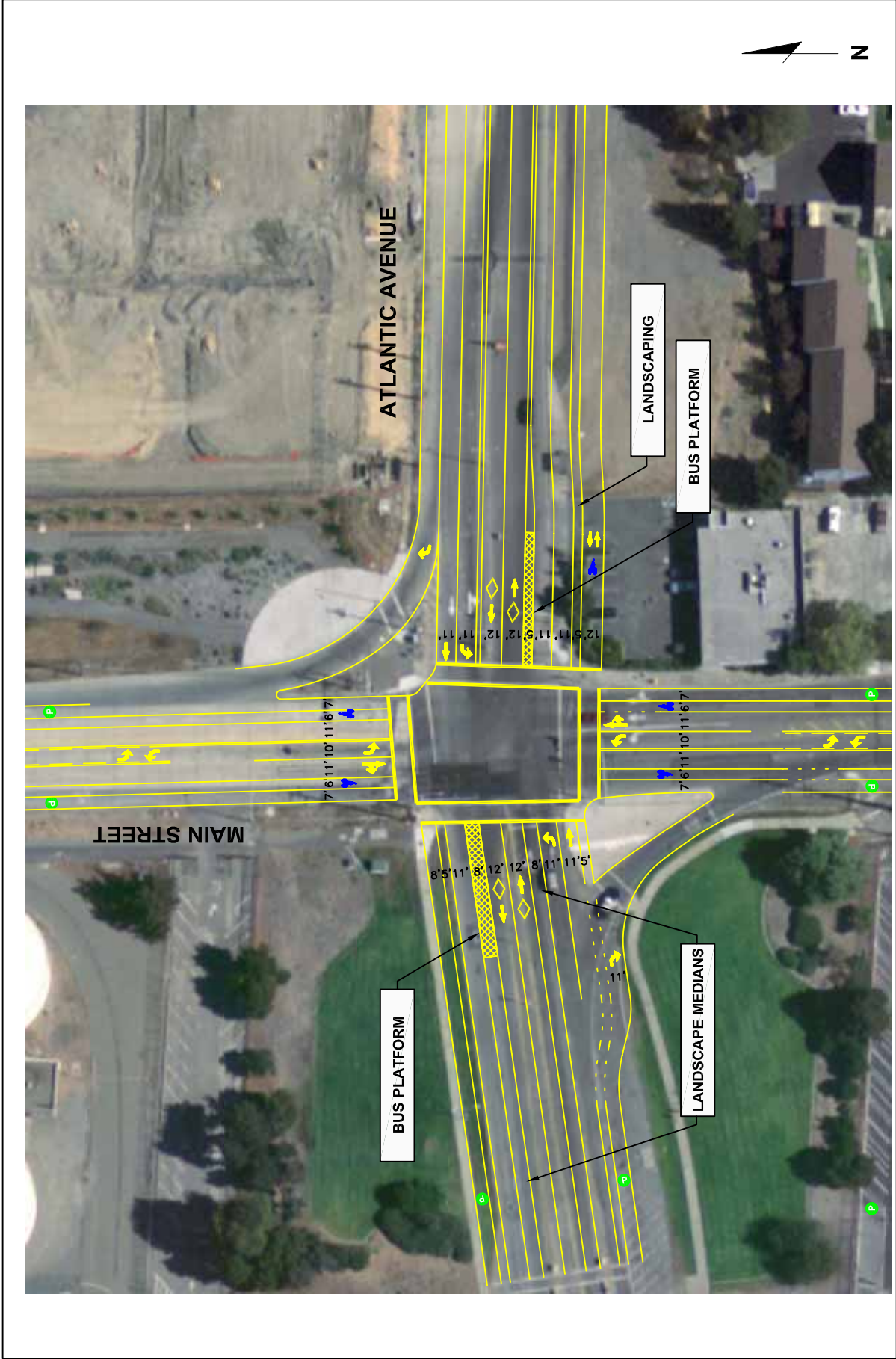

Alameda Land Use Planning
**PROPOSED CONCEPT DESIGN OF
 ATLANTIC AVENUE/MAIN STREET**
FIGURE 15

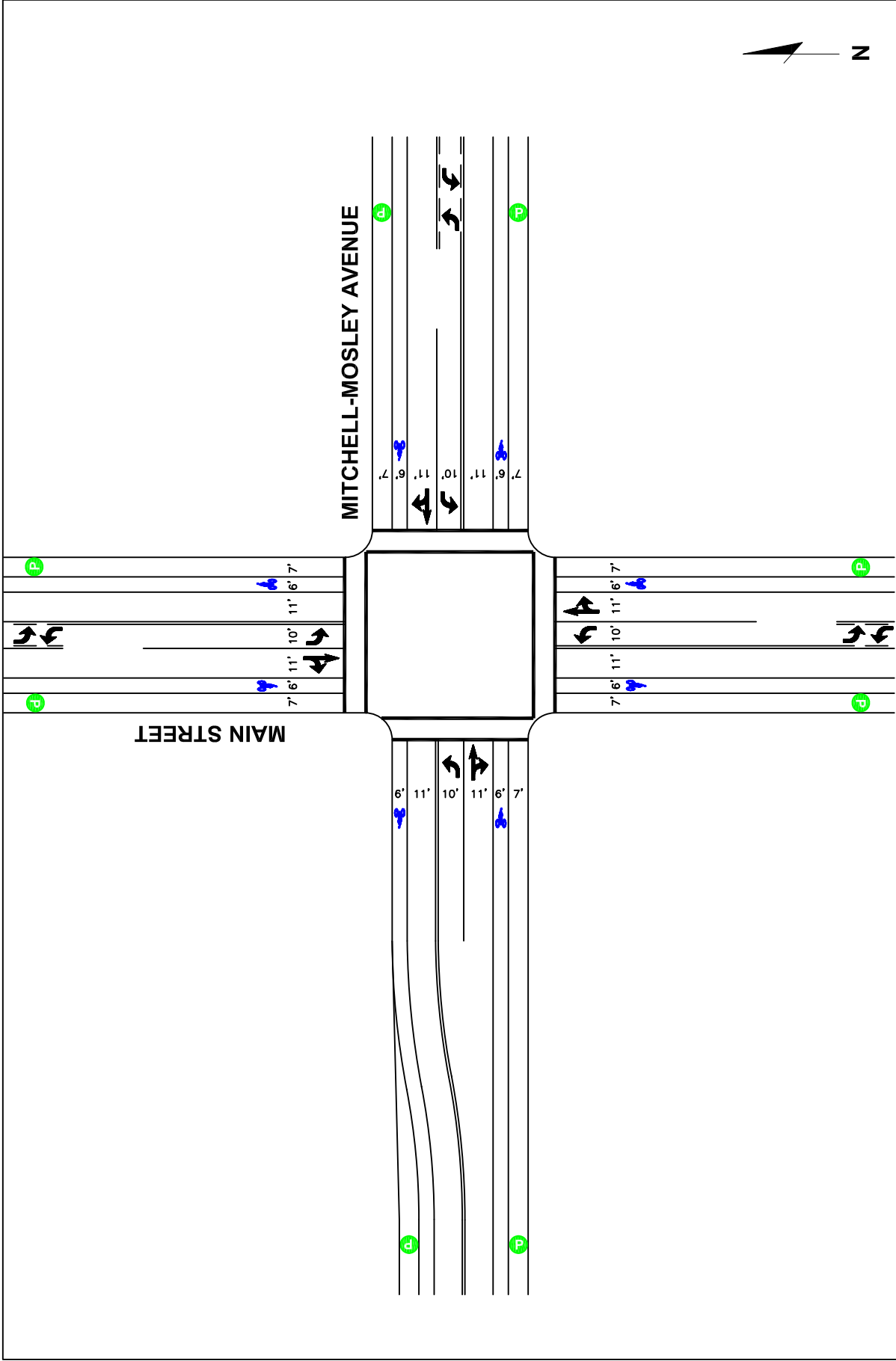

**PROPOSED CONCEPT DESIGN OF
MITCHELL-MOSELY AVENUE/MAIN STREET
FIGURE 17**

SECTION IV– Previous Travel Demand Forecasting Report (7/03)

I. INTRODUCTION

This chapter discusses the study purpose, organization of this report, and the methodology used to forecast the travel demand that would be generated by the proposed redevelopment of Alameda Point, the net increase in off-site vehicle trips and the resulting level of service (LOS) for motor vehicle traffic at study intersections.

A. Study Purpose

The purpose of this report is to present the findings and recommendations of a travel demand forecast and transportation impact analysis conducted by Fehr & Peers for the proposed redevelopment of Alameda Point (the "Project"). The Project site is located on the west end of the Island of Alameda, which is the former Alameda Naval Air Station and Fleet Industrial Supply Center (see Figure 1).

The Project will emphasize mixed-use development and transportation demand management (TDM) strategies to minimize off-site vehicle trips, as summarized in the *Alameda Point Transportation Strategy Report*. The Project site plan is shown on Figure 2. This study evaluates the off-site transportation system impacts associated with the Project and provides a general assessment of site access and on-site circulation.

B. Report Organization

This report is divided into six chapters as described below:

Chapter I – Introduction discusses the purpose and organization of this report.

Chapter II – Existing Conditions describes the operating conditions of the existing transportation network in the project vicinity, including the surrounding roadway network, weekday AM and PM peak-hour traffic volumes, and intersection levels of service. This study uses information contained in the *General Plan Amendment Environmental Impact Report*, re-issued in 2002, and traffic counts provided by the City of Alameda in July 2003.

Chapter III – Cumulative (Year 2020) Plus Project Conditions presents relevant Project information with respect to transportation impacts, such as estimated Project trip generation, geographic distribution of new trips, and their assignment to the roadway network. This chapter also addresses the long-term future (Year 2020) conditions and discusses potential project-related contributions and impacts to long-term expected traffic conditions.

Chapter IV – Conclusions and Recommendations summarizes the results of the analysis and makes recommendations. This chapter also provides an overview of the proposed Project's access and on-site circulation provisions.

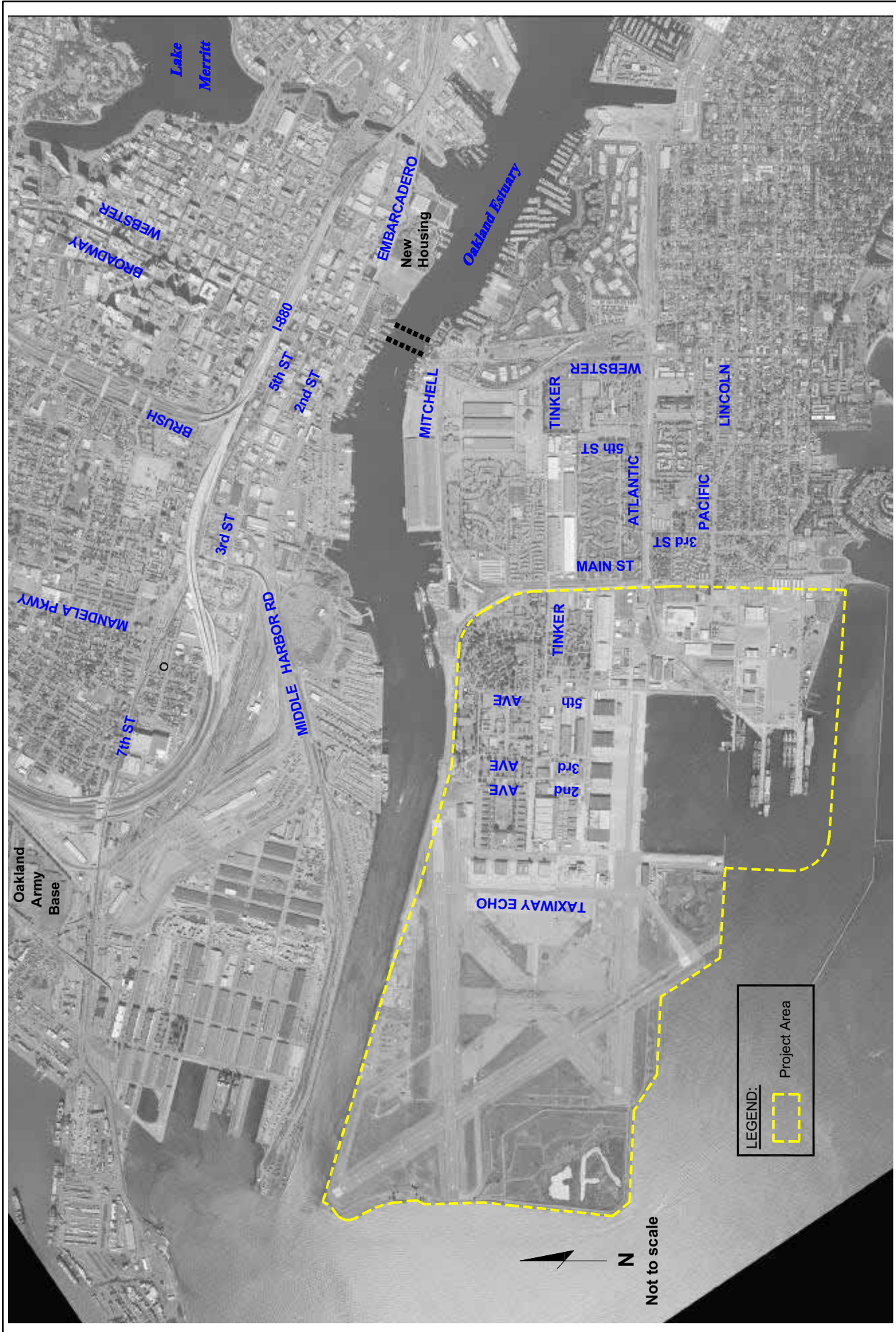

Alameda Point

STUDY AREA
FIGURE 1



FEHR & PEERS
TRANSPORTATION CONSULTANTS

June 2003
1027-0035\graphics\0035A-40

Alameda Point

SITE PLAN

FIGURE 2

C. Study Intersections

The most common form of analyzing traffic impacts is to examine operations of key intersections near the proposed project. The intersections listed below were chosen for analysis in consultation with the Public Works Director and staff from the City of Alameda. This study will analyze a total of 31 study intersections. Intersections 1 through 18 are existing intersection within the island of Alameda. Intersections 19 through 21 are located in Oakland. Intersections 22 through 32 (indicated in bold) would be created by the Project. The locations of existing intersections are shown on Figures 3 and 4, and the proposed future roadway network and new study intersections are shown on Figures 6 and 7.

- 1) Atlantic Avenue / Main Street
- 2) Atlantic Avenue / Third Street
- 3) Atlantic Avenue / Poggi Street
- 4) Atlantic Avenue / West Campus Drive
- 5) Atlantic Avenue / Webster Street
- 6) Constitution Way / Atlantic Avenue
- 7) Constitution Way / Marina Village Parkway
- 8) Main Street / Pacific Avenue
- 9) Webster Street / Lincoln Avenue
- 10) Constitution Way / Lincoln Avenue
- 11) Webster Street / Central Avenue
- 12) Central Avenue / Eighth Street
- 13) Pan Am Way / Atlantic Avenue
- 14) Main Street / West Tower Avenue
- 15) Main Street / West Midway Avenue
- 16) Main Street / Singleton Avenue
- 17) Main Street / Navy Way
- 18) Pan Am Way / West Midway Avenue
- 19) Webster Street / 7th Street
- 20) Harrison Street / 7th Street
- 21) Jackson Street / 6th Street
- 22) Pan Am Way / Main Street**
- 23) Main Street / Ticonderoga Avenue**
- 24) Main Street / Mitchell-Mosley**
- 25) Webster Street / Tinker Avenue**
- 26) Tinker Avenue / Marina Square Loop**
- 27) Tinker Avenue / Fifth Street**
- 28) Fifth Street / Mitchell-Mosley**
- 29) Mitchell-Mosley / Marina Square Loop**
- 30) Webster Street / New College Driveway**
- 31) Atlantic Avenue / Fifth Street**

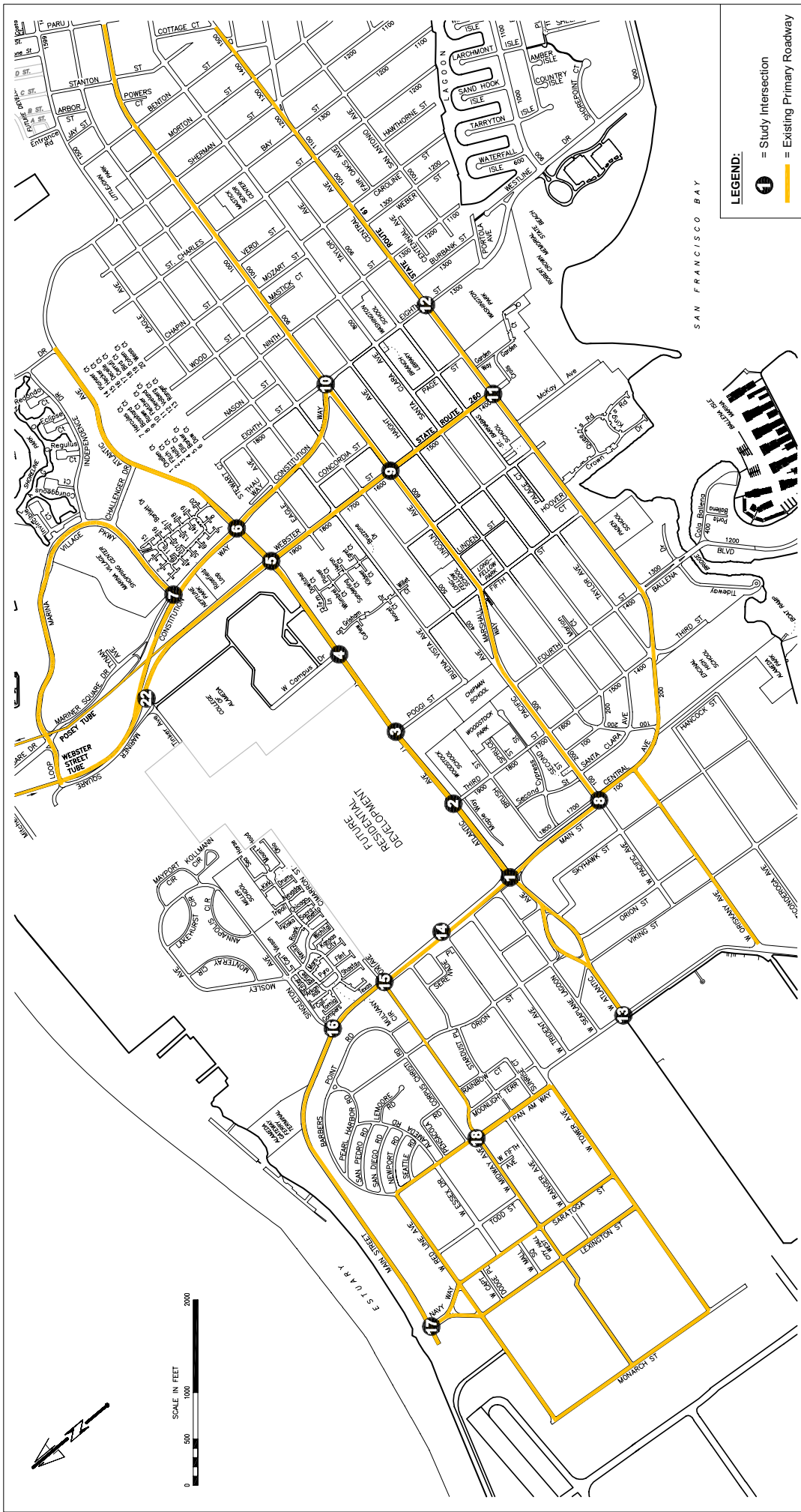

Alameda Point
**EXISTING ROADWAY NETWORK
 AND ALAMEDA STUDY INTERSECTIONS**
FIGURE 3



Alameda Point

OAKLAND STUDY INTERSECTIONS
FIGURE 4

D. Analysis Methodology

The analysis methodology outlined in the *2000 Highway Capacity Manual* (HCM), published by the Transportation Research Board, was utilized for the analysis of intersection operating conditions.

1. Level of Service Criteria

To measure and describe the operational status of the local roadway network, transportation engineers and planners commonly use a grading system called level of service (LOS). LOS is a qualitative description of an intersection's operation, ranging from LOS A (indicating free-flow traffic conditions with little or no delay) to LOS F (representing over-saturated conditions where traffic flows exceed design capacity, resulting in long queues and delays).

2. Signalized Intersections

At signalized intersections, traffic conditions are evaluated using the methodology described in Chapter 16 of the *2000 Highway Capacity Manual* (HCM). This methodology determines the LOS rating based on the average "control delay" experienced at the intersection (in seconds per vehicle). "Control delay" refers to the delay imparted to vehicles by a traffic control device (a traffic signal or a stop sign). This "control delay" includes delay caused by a vehicle's initial deceleration at a signal, queue move-up time, stopped delay, and final acceleration. The ultimate result of "control delay" is the difference in travel time that a vehicle actually experiences versus the travel time that a vehicle would experience if there were no other vehicles or control devices at the intersection.

The average control delays for the various signalized study intersections were calculated using the Traffix analysis software. This software is consistent with the methodologies prescribed in the 2000 Edition of the HCM and correlates the average delay to the appropriate level of service designations (ratings). Table 1 summarizes the relationship between the delay and LOS for signalized intersections.

3. Unsignalized Intersections

For unsignalized intersections (including both all-way stop-controlled and side street stop-controlled), the Transportation Research Board's *2000 Highway Capacity Manual* methodology for unsignalized intersections was utilized. With this methodology, operations are defined by the average control delay per vehicle (measured in seconds) for each stop-controlled movement. The method incorporates delay associated with deceleration, acceleration, stopping, and moving up in the queue. For side street stop-controlled intersections, delay is typically represented for each movement from the minor (stop-controlled) approaches only. Table 2 summarizes the relationship between delay and LOS for unsignalized intersections.

Table 1 Signalized Intersection Level of Service Definitions		
Level of Service	Signalized Intersection	Average Control Delay (sec / veh)
A	Insignificant Delays: No approach phase is fully utilized and no vehicle waits longer than one red indications.	≤ 10
B	Minimal Delays: An occasional approach phase is fully utilized. Drivers begin to feel restricted.	> 10 – 20
C	Acceptable Delays: Major approach phase may become fully utilized. Most drivers feel somewhat restricted.	> 20 – 35
D	Tolerable Delays: Drivers may wait through no more than one red indication. Queues may develop but dissipate rapidly, without excessive delays.	> 35 – 55
E	Significant Delays: Volumes approaching capacity. Vehicles may wait through several signal cycles and long vehicle queues from upstream.	> 55 – 80
F	Excessive Delays: Represents conditions at capacity, with extremely long delays. Queues may block upstream intersections.	> 80

Source: *Highway Capacity Manual*, Transportation Research Board, 2000.

Table 2 Unsignalized Intersection Level of Service Definitions		
Level of Service	Unsignalized Intersection	Average Control Delay (sec / veh)
A	No delay for stop-controlled approaches.	0 - 10
B	Operations with minor delay.	> 10 – 15
C	Operations with moderate delays.	> 15 – 25
D	Operations with some delays.	>25 - 35
E	Operations with high delays, and long queues.	> 35 – 50
F	Operation with extreme congestion, with very high delays and long queues unacceptable to most drivers.	> 50

Source: *Highway Capacity Manual*, Transportation Research Board, 2000.

4. Significance Criteria

Based on the City of Alameda standard thresholds of significance, a significant traffic-related impact would occur if the addition of new traffic as a result of a project would result in intersection operations deteriorating from an acceptable level (LOS D or better) to an unacceptable level (LOS E or worse).

II. EXISTING CONDITIONS

The following chapter provides a description of the existing traffic and circulation conditions within the vicinity of the proposed Project site.

A. Study Area

The Project is located at the west end of the island of Alameda (see Figure 1). Local access to Alameda Point is provided by the island's street grid. All regional access to Alameda and the Project site is provided via local roadways in Alameda and the City of Oakland. Regional access to and from the Project site is available at Interstate 880 (I-880) and Interstate 980 (I-980) via Oakland city streets. I-880 provides access to the south and to the north, with connections to Interstate 80 (I-80) and San Francisco via the Bay Bridge. I-980 provides access to the northeast, connecting with Interstate 580 (I-580) and State Route 24 (SR 24).

The primary regional access between the Project site and I-880/I-980 is State Route 260 (SR 260), which includes the inbound Webster and outbound Posey Tubes. The Webster and Posey Tubes connect the City of Alameda with the City of Oakland. The Webster Tube is two lanes in the south-bound direction from Oakland to Alameda, while the Posey Tube provides two lanes in the north-bound direction, from Alameda to Oakland. Access between Alameda and the freeways, through the Tubes, is available by traveling on local streets in downtown Oakland.

Both the cities of Alameda and Oakland are constructed as grids, with east-west and north-south roadways traversing the cities (see Figures 3 and 4). Five of the six roadways described below are part of the Metropolitan Transportation System (MTS). MTS routes are comprised of facilities and services that are considered essential for regional mobility. Some of the MTS arterial street and highway system criteria are listed below:

- Provides access to the major central business districts, major activity centers or major employment destination;
- Provides mobility and accessibility within and around major central business districts or other major areas of high density;
- Provides key alternative for local trips parallel to freeway; and
- Provides access to major freight transfer facilities.

Important roadways within the Project area include:

- *Webster Street and Constitution Way* – Traffic entering Alameda via the Webster Tube is routed onto either Webster Street or Constitution Way. These roadways are also used to depart Alameda by entering the Posey Tube. Webster Street is a four-lane major street with left turn pockets provided; it terminates at Central Avenue. Constitution Way is also a four-lane major street with turn pockets until it reaches Lincoln Avenue where it terminates at the Lincoln Avenue/Eighth Street intersection. South of Lincoln Avenue, Eighth Street connects Constitution Way to Central Avenue. Signals are located at major streets that cross these roadways, such as Atlantic Avenue, Lincoln Avenue, Santa Clara Avenue and Central Avenue. Both Webster Street and Constitution Way are part of the MTS.

- *Atlantic Avenue* – This is a major east-west street that serves as the primary access into and out of Alameda Point. The roadway provides two travel lanes in each direction west of Constitution Way and one travel lane in each direction between east of Constitution Way, where it becomes Sherman Street. Left turn pockets are provided at major intersections along its entire length. The portion between Main Street and Constitution Way is part of the MTS.
- *Main Street* – The primary access and frontage road to Alameda Point is Main Street, which intersects with Atlantic Avenue at the eastern end of the Alameda Point area. Main Street has four travel lanes with no exclusive left-turn lanes. Signals are provided at Main Street/Atlantic Avenue, Main Street/West Midway Avenue, Main/Singleton (Coast Guard Housing), Main/Ferry Terminal, and Main Street/Pacific Avenue, also known as Main Street/Central Avenue. Main Street is part of the MTS roadway system.
- *Pacific Avenue/Lincoln Avenue* – This four-lane major roadway provides access to other portions of Alameda east of the Project. It is named Pacific Avenue between Main Street and 4th Street; east of 4th Street, Pacific Avenue splits, with its southerly branch becoming Marshall Way, which then becomes Lincoln Avenue at 5th Street. Lincoln Avenue continues east as a four-lane collector until it terminates at High Street. At Park Street, Lincoln Avenue intersects with Tilden Way, providing direct access to the Fruitvale (Miller/Sweeney) Bridge.
- *Central Avenue* – This primary east-west major street is considered an MTS roadway between Main Street and Park Street. It is designated as State Route 61 between Webster Street and Sherman Street and continues as a two-lane major street east of Sherman Street. SR 61 continues as a four-lane roadway east of Sherman Street on Encinal Avenue.

Five streets enter and exit Alameda Point: Main Street, Midway Avenue, Atlantic Avenue, Pacific Avenue, and West Oriskany Avenue. Each of these access routes or roadways is one lane in each direction except for Atlantic Avenue, which has two lanes in each direction.

Within the Project site, West Red Line Avenue, West Midway Avenue, West Tower Avenue, and Atlantic Avenue are east-west streets that link the former airfield and light industrial areas to the central core and residential areas. Lexington Street, Saratoga Street, Pan Am Way, and Orion Street provide north-south access from the pier facilities along the southern side of the site to the central portion of the site. Main Street also provides both east-west access and north-south access for the Project.

There are no signalized intersections within the Project; most of the intersections are stop sign controlled on the minor street approaches. The only signalized intersections are adjacent to Alameda Point on Main Street at West Midway Avenue, Atlantic Avenue, Pacific Avenue, Singleton Avenue and Ferry Terminal access road. The current Alameda Point street system is shown in Figure 3.

On the Oakland side, major north-south streets used or traveled by Alameda traffic include Broadway, Jackson Street, Webster Street, Harrison Street, Franklin Street, Madison Street and Oak Street. Generally, these streets (except Broadway and Jackson Street) are one-way streets. Major cross-streets are numbered and these also generally run in a one-way direction, such as 5th, 7th, 8th, 11th and 12th Streets. Traffic from western Alameda, including Alameda Point, contributes to traffic volumes on these streets, although the majority of Downtown Oakland traffic is locally-generated.

The Webster and Posey Tubes connect the City of Alameda with the City of Oakland. Access to the Webster Tube in Oakland occurs via two access points: southbound Webster Street at 7th Street and Broadway at 5th Street. Traffic exiting I-980 typically travels down Brush Street to 5th Street, and then left on 5th Street to Broadway. Traffic from I-880 southbound typically uses the Broadway/Alameda exit and from Adeline Street turns right onto 5th Street. Traffic exiting I-880 northbound exits at Broadway, turns right onto 7th Street, and then turns right again onto Webster Street.

Traffic leaving Alameda via the Posey Tube enters the City of Oakland at 7th and Harrison Streets. From this point, traffic accessing I-880 southbound is directed to travel eastbound on 7th Street to Madison Street, turning right on southbound Madison Street, then left on eastbound 5th Street to the freeway on-ramp south of Oak Street. Traffic accessing I-880 northbound travels eastbound on 7th Street, turns right onto Jackson Street, and then turns right onto the I-880 Jackson Street on-ramp. Traffic accessing I-980 northbound may follow the I-880 northbound path, or use Downtown Oakland streets to reach the on-ramp at 12th and Castro Streets.

B. Existing Traffic Counts

The traffic counts utilized to document existing conditions were gathered from several sources, including:

- City of Alameda comprehensive intersection traffic count survey conducted in the fall of 2000, which was supplemented in 2002 with 15 additional intersections;
- AM and PM peak hour traffic counts at select Alameda and Oakland intersections conducted by Fehr & Peers in May 2001; and
- Recent City of Oakland traffic studies for select Downtown Oakland intersections conducted in April, 2002.

Figure 5 displays the traffic control (stop signs or traffic signals), lane configurations and peak-hour traffic volumes for the 18 study intersections located in Alameda and the three study intersections located in Oakland.

C. Intersection Levels of Service

Levels of service were calculated at each study intersection during both the AM and PM peak hours (see Appendix for detailed level of service calculations). Table 3 lists the resulting level of service and corresponding delay at each study intersection. Levels of service in bold represent unacceptable (LOS E or F) operating conditions.

As shown in Table 3, all study intersections currently operate acceptably during both peak hours, therefore meeting the City of Alameda's level of service threshold (LOS D). Two (2) of the 18 study intersections located in Alameda currently operate at LOS D during both peak hours. Additionally, the Jackson Street / 6th Street intersection in Oakland currently operates at LOS D in the AM peak hour.

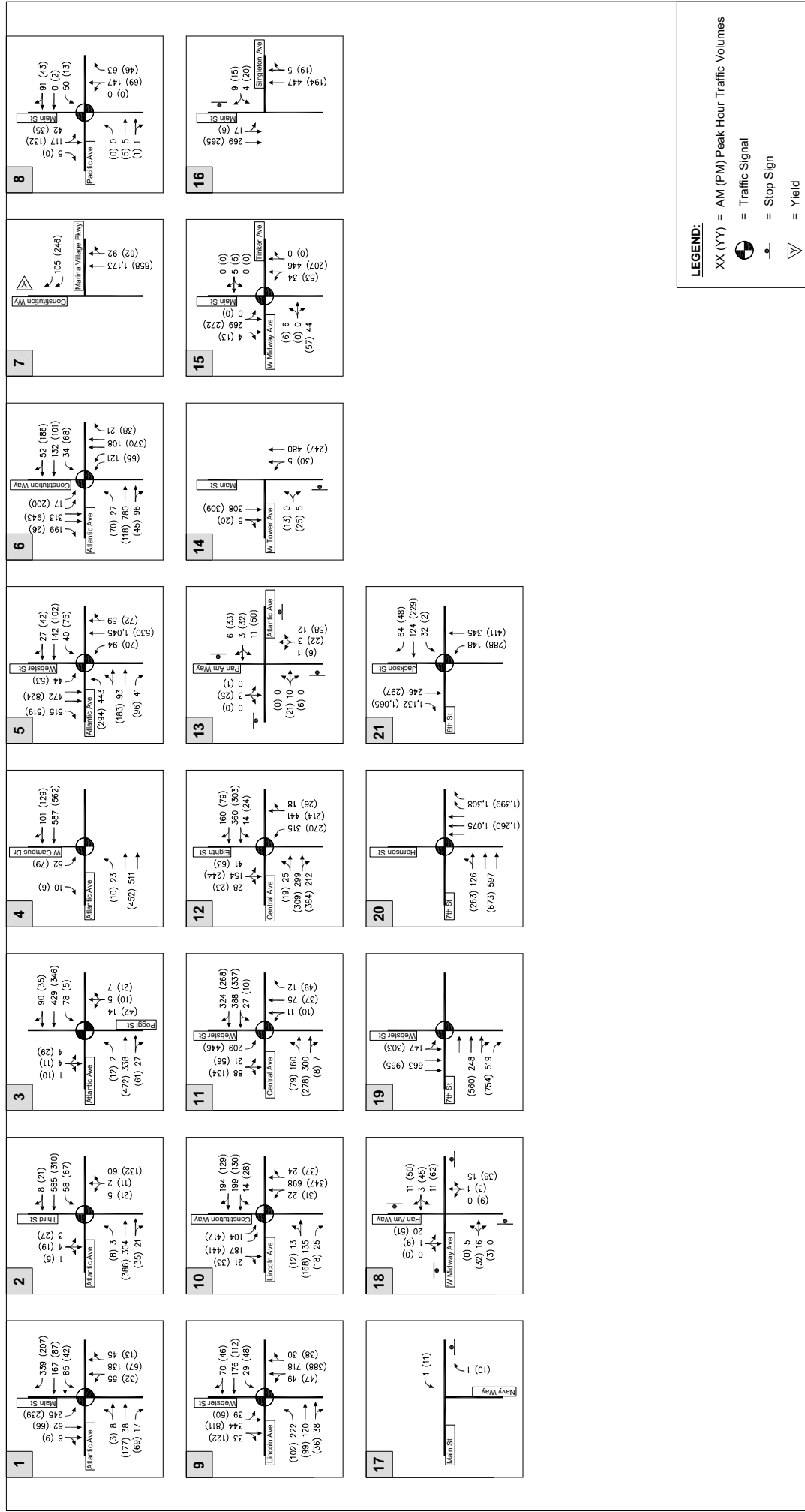

**Table 3
Intersection Levels of Service
Existing Conditions**

No.	Intersection	Traffic Control	LOS / Delay (Sec. / Veh.)	
			AM Peak Hour	PM Peak Hour
1	Atlantic Avenue / Main Street	Traffic Signal ¹	B (12.2)	C (20.9)
2	Atlantic Avenue / Third Street	Traffic Signal	A (7.4)	B (11.3)
3	Atlantic Avenue / Poggi Street	Traffic Signal	A (6.2)	A (7.3)
4	Atlantic Avenue / West Campus Drive	Traffic Signal	A (9.4)	A (9.4)
5	Atlantic Avenue / Webster Street	Traffic Signal	D (35.1)	D (44.5)
6	Atlantic Avenue / Constitution Way	Traffic Signal	D (37.7)	D (41.5)
7	Constitution Way / Marina Village Parkway	Side-Street Stop-Controlled	B (14.5)	B (15.0)
8	Main Street / Pacific Avenue	Traffic Signal	A (7.4)	B (10.3)
9	Webster Street / Lincoln Avenue	Traffic Signal	A (8.6)	A (8.2)
10	Constitution Way / Lincoln Avenue	Traffic Signal	C (28.5)	C (26.2)
11	Webster Street / Central Avenue	Traffic Signal	B (15.7)	B (14.5)
12	Central Avenue / Eighth Street	Traffic Signal	C (26.5)	C (31.3)
13	Pan Am Way / Atlantic Avenue	AWSC ²	A (7.4)	A (6.8)
14	Main Street / West Tower Avenue	Side-Street Stop-Controlled	A (9.7)	B (10.6)
15	Main Street / West Midway Avenue / Tinker Avenue	Side-Street Stop-Controlled	C (16.5)	B (14.1)
16	Main Street / Singleton Avenue	Side-Street Stop-Controlled	B (10.9)	A (9.5)
17	Main Street / Navy Way	Side-Street Stop-Controlled	A (0.0)	A (0.0)
18	Pan Am Way / West Midway Avenue	AWSC	A (7.7)	A (7.0)
19	Webster Street / 7 th Street	Traffic Signal	A (8.6)	A (9.9)
20	Harrison Street / 7 th Street	Traffic Signal	A (8.0)	A (8.8) ³
21	Jackson Street / 6 th Street	Traffic Signal	D (36.8)	C (30.6) ⁴

Notes:

¹ Signalized intersection LOS based on average intersection delay, based on the methodology in the *Highway Capacity Manual*, 2000 Edition.

² All-way stop-controlled intersection LOS based on average intersection delay, based on the methodology in the *Highway Capacity Manual*, 2000 Edition.

³ Although the resulting LOS indicates acceptable traffic operations, vehicle queues occur on the northbound approach and extend into the Posey tunnel. This is largely due to the heavy traffic movement from the island to the I-880 on-ramp at the Jackson Street / 6th Street intersection.

⁴ Similar to the Harrison Street / 7th Street intersection, this intersection experiences extensive vehicle queues on its southbound approach (particularly the right-turn movement) due to the heavy traffic from the island to the I-880 on-ramp.

Source: Fehr & Peers, June 2003.

Although the three Oakland study intersections currently operate acceptably under both peak hours, extensive vehicle queues occur at each intersection, particularly for the movement exiting from the Posey tube to the I-880 on-ramp at Jackson Street / 6th Street intersection. Field observations indicate that vehicle queues for the southbound right-turn movement at the Jackson Street / 6th Street intersection spillback to the Jackson Street / 7th Street and Harrison Street / 7th Street intersections. All other study intersections operate acceptably at LOS C or better.

III. CUMULATIVE (YEAR 2020) PLUS PROJECT CONDITIONS

This chapter describes the potential transportation impacts associated with the proposed redevelopment of Alameda Point and the expected changes to traffic operations under cumulative (Year 2020) conditions, assuming redevelopment of Alameda Point, cumulative growth in Alameda and planned transportation improvements. This chapter also describes the methodology used to develop future traffic volumes and presents the corresponding level of service calculations for each study intersection.

The proposed redevelopment of Alameda Point would have the following site characteristics:

- 1,634 housing units (157 multi-unit, 142 duplexes, and 1,335 single-family residential)
- 700,000 square feet of office use
- 300,000 square feet of retail space
- Adaptive reuse of the hangers (approximately 88,000 square feet of retail space, 460,000 square feet of office, 1.24 million square feet of warehouse, 770,000 square feet of manufacturing, and 137,000 square feet of research and development uses)

A. Proposed Roadway Network

Several planned and programmed transportation improvements have been assumed as part of this traffic analysis. The assumed roadway improvements within the vicinity of the study are highlighted in Figure 7.

Alameda Roadway Improvements. Three additional roadway improvements are planned to be constructed in the vicinity of Alameda Point, and will result in additional east-west streets that will connect Alameda Point with the remainder of the island. All three are assumed to be in place by 2020. These improvements include the following:

- *Tinker Avenue Extension.* This roadway project will provide a new entry point into the Project site. The new Tinker Avenue extension will have a signalized intersection at Webster Street, from which a two-way four-lane facility will provide access to Main Street and Alameda Point.
- *The Mitchell/Mosley Connector.* This roadway will also provide a new entry point into the Project site. This facility will link two two-lane roadways, enabling a continuous flow from the Marina Village area to Alameda Point. This facility will be completed with local development funding.
- *Broadway/Otis Drive and High Street/Otis Drive Intersection Channelization Improvements.* This project is currently under construction by Caltrans. It includes installation of left-turn pockets in both the eastbound and westbound directions at Broadway and High Street along Otis Drive and signal modifications to include an exclusive left-turn phasing.

Other roadway improvements also assumed in Alameda include:

- *Fifth Street Extension.* This proposed north-south roadway will consist of four lanes and will be located east of the Webster-Posey Tubes. This roadway will provide additional access to the Marina Village area from Alameda Point. Fifth Street would extend from Atlantic Avenue to the

south, through Tinker Avenue and terminate at Mitchell-Mosley to the north. Traffic signals would be installed at all three intersections.

- *College Driveway / Webster Street Intersection.* This signalized T-intersection will provide direct access to the College of Alameda from Webster Street. Webster Street is currently a four-lane roadway and will provide exclusive left and right-turn lanes into the College driveway.
- *Mariner Square Loop Realignment.* This roadway currently runs parallel to the Webster Street tube. The proposed realignment will extend the roadway to the proposed signalized Tinker Avenue and Webster Street intersection. This roadway will also provide access to the proposed development just north of Tinker Avenue.

The construction of the proposed improvements in Alameda would result in 10 new signalized intersections. Based on consultation with City staff, all 10 intersections have been selected for analysis under cumulative plus Project conditions in addition to the 21 existing study intersections. The proposed intersections to be built under cumulative conditions are provided below and their locations are shown in Figure 7.

- Webster Street / Tinker Avenue
- Main Street / Pan Am Way
- Main Street / Mitchell-Moseley
- Fifth Street / Mitchell-Moseley
- Mitchell-Moseley / Marina Square Loop
- Tinker Avenue / Fifth Street
- Tinker Avenue / Marina Square Loop
- Webster Street / New College Driveway
- Atlantic Avenue / Fifth Street
- Main Street / Ticonderoga Avenue

I-880 Corridor – Broadway/Jackson Improvements. In November 2000, voters in Alameda County approved Measure B to continue the ½ cent sales tax to fund transportation programs and projects. The I-880/Broadway-Jackson Street Interchange Improvements Project was one of the capital projects included in the Measure's 20-Year Transportation Expenditure Plan. The purpose of these improvements is to improve mobility between Alameda and Oakland and to improve access from the Jack London Square District, Chinatown, downtown Oakland and City of Alameda to I-880/980.

In June 2000, Caltrans approved a Project Study Report (PSR) for the I-880/Broadway-Jackson Street-Phase 1 Interchange Improvements. This PSR recommended proceeding into the Project Approval/Environmental Document (PA/ED) Phase of Project Development with six project elements. The PSR identified a feasible ramp improvement from Jackson Street to northbound I-880; however, this element was eliminated from further consideration during the PA/ED phase. Consequently, the current PA/ED is proceeding with five project elements, and these elements constitute Phase 1 of this project.

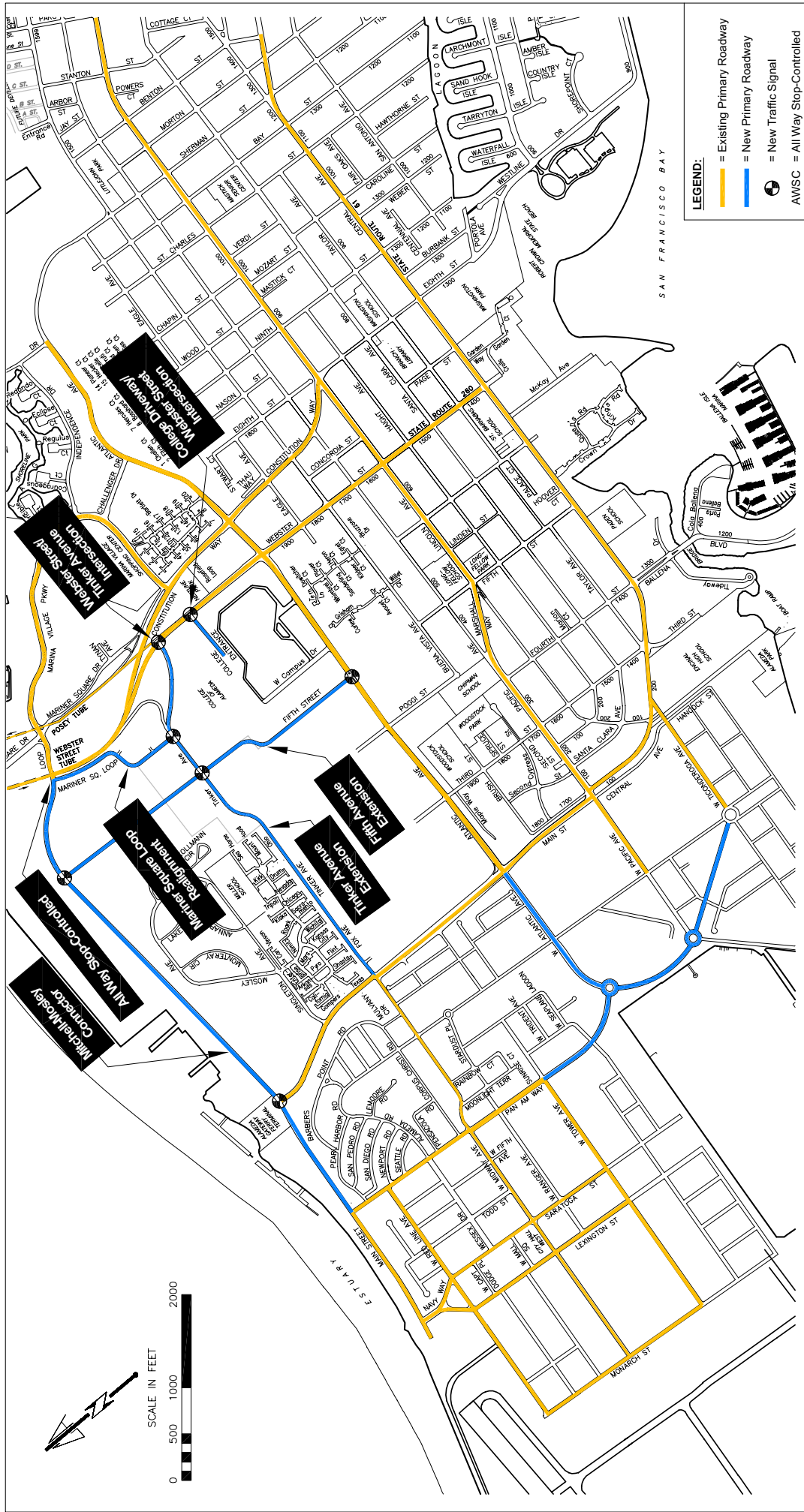

Alameda Point

**PROPOSED ROADWAY NETWORK
FIGURE 6**

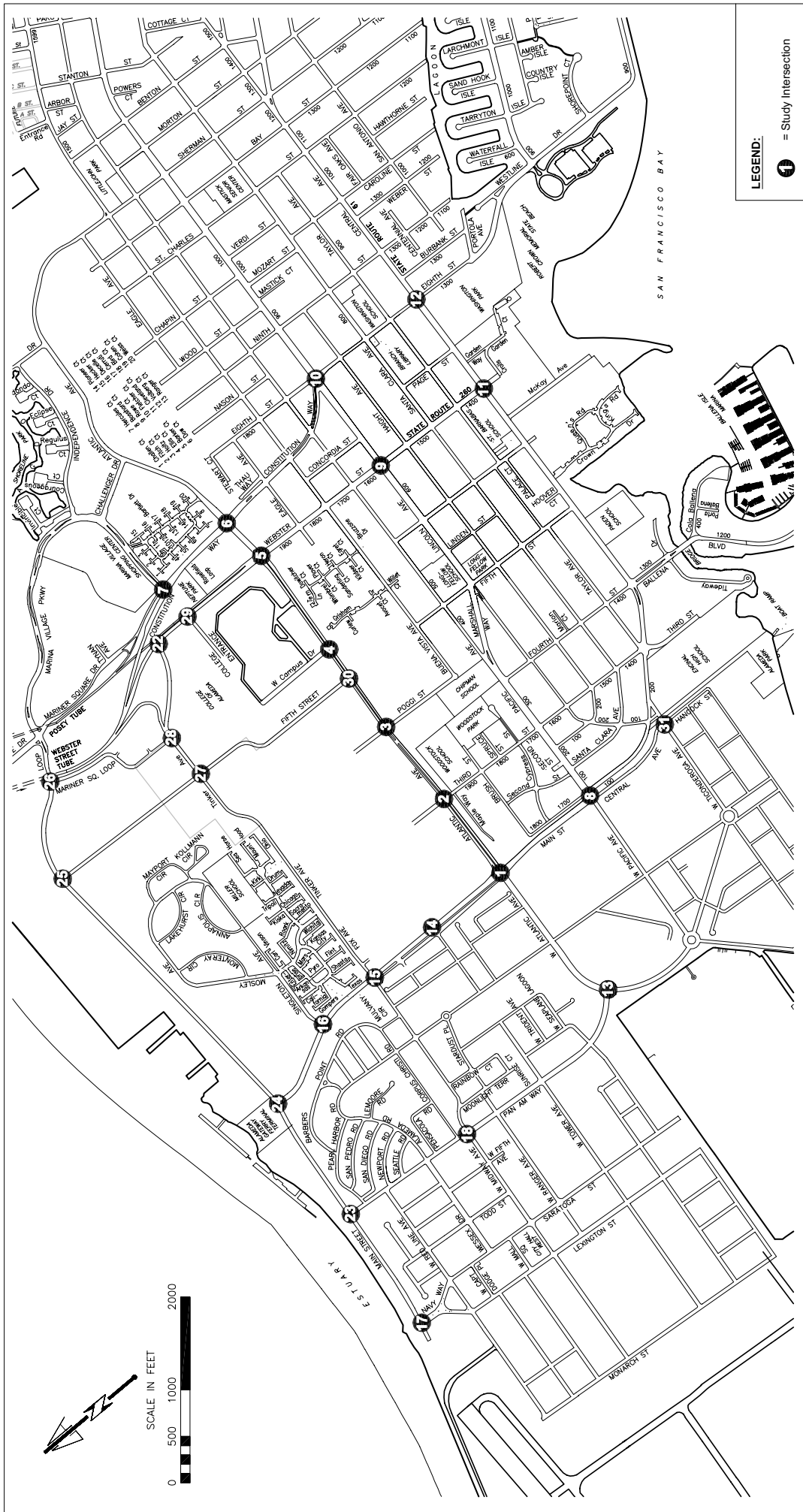

Alameda Point

PROPOSED ROADWAY STUDY INTERSECTIONS
FIGURE 7

LEGEND:
 = Study Intersection

The proposed elements included in Phase I of the Broadway/Jackson improvements (and shown in Figure 8) are as follows:

- Construct a new southbound off-ramp for I-880 to Martin Luther King, Jr. Way;
- Improve the northbound Jackson Street on-ramp to I-880;
- Create a dual left turn from southbound Broadway at the intersection of Broadway and 5th streets;
- Improve the existing traffic operation system to better manage traffic flow between the Posey/Webster Tubes and I-880 and I-980; and
- Provide improved signage to direct traffic from I-880/I-980 to Downtown Oakland, Jack London Square, Chinatown, and the City of Alameda.

These elements are anticipated to be completed after 2005, but before 2020, and are assumed in the 2020 traffic model projections.

As identified in the Countywide Transportation Plan prepared by the Alameda County CMA, the preliminary estimated capital cost for this Phase I project is \$24.5 million. Funding will derive from the County share of the State Transportation Improvement Program (STIP), corridor management funding and Measure B.

As part of the June 2000 PSR, Caltrans analyzed a number of potential connections to I-880 from the Posey/Webster Tubes. Based upon Caltrans' initial analysis, a combination of factors were identified which raised questions about the feasibility of the direct connection alternatives being considered (e.g., costs, environmental impacts, right of way impacts, geometric issues and safety issues). Therefore, these alternatives were not further developed. At that time, both the cities of Alameda and Oakland accepted the deferral of further study of these alternatives for a future PSR in order to maintain the Project Development Process for the remaining mutually acceptable improvements. The cities of Alameda and Oakland are currently working with the CMA and Caltrans to develop a new PSR to accomplish the intent of the original alternatives. These new alternatives would potentially be part of Phase II of this project and are not assumed in this analysis.

I-880 Access Improvements of High Street/42nd Avenue. A project to improve access for vehicles traveling between I-880 and the cities of Oakland and Alameda via 42nd Avenue and High Street is currently in design. The currently preferred alternative is the 42nd Avenue to High Street connection, defined as Alternative B in the Project Study Report/Project Report published on December 18, 2000. This alternative is currently funded by the Alameda Countywide Transportation Plan as a Tier 1 funded improvement and is assumed to be completed by 2020.

B. Cumulative (Year 2020) Land Use Assumptions

To estimate cumulative background traffic growth in Alameda and within the Project site, this study utilized a refined version of the Alameda County Congestion Management Agency's Countywide Transportation Demand Model, as developed for the City of Alameda for use in their recent General Plan update. The model requires projections of demographic and socioeconomic characteristics, such as population, income, and employment, in order to forecast future travel patterns. Land use inputs were drawn from projections produced by the Association of Bay Area Governments (ABAG) in

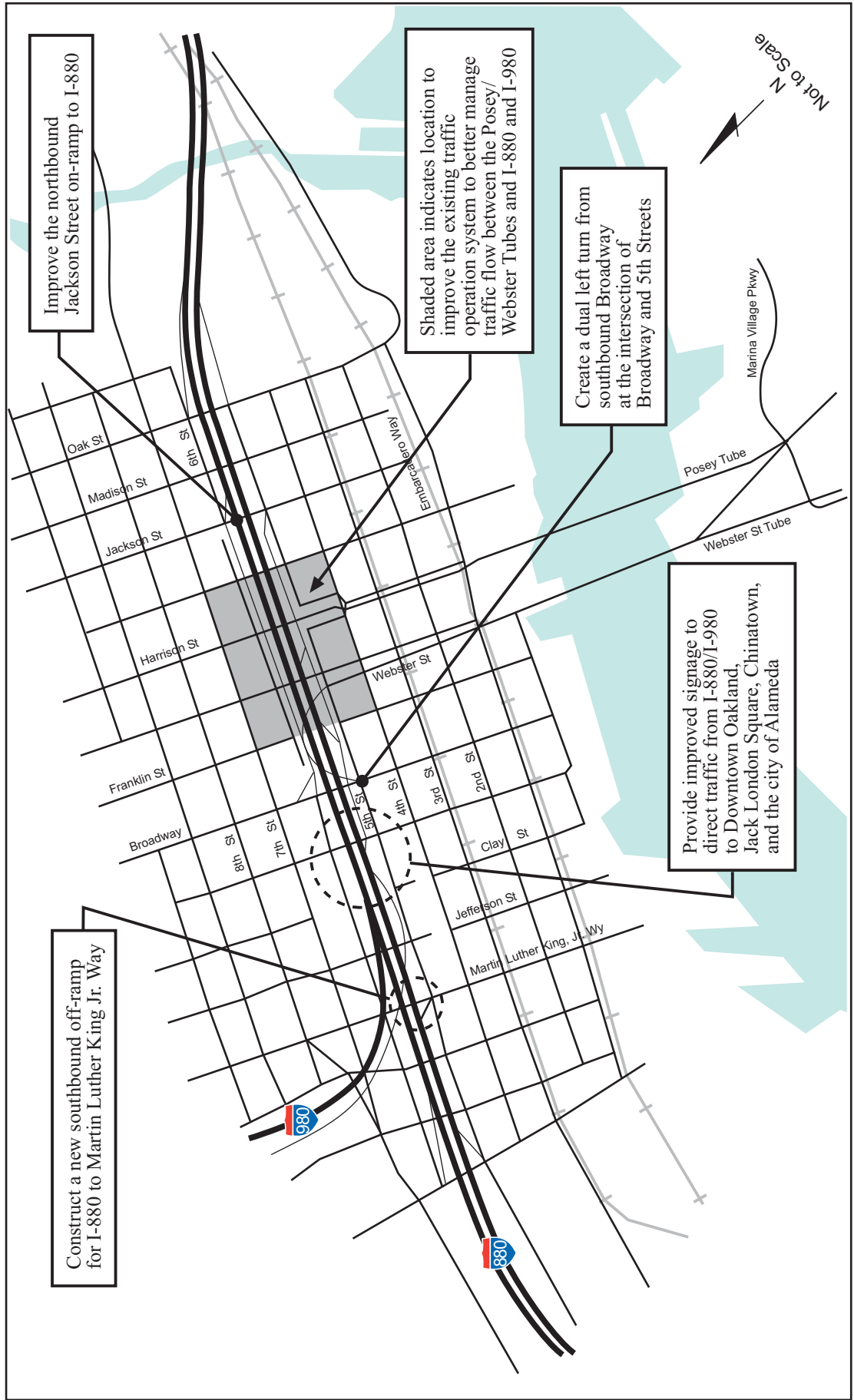

Improve the northbound Jackson Street on-ramp to I-880

Shaded area indicates location to improve the existing traffic operation system to better manage traffic flow between the Posey/ Webster Tubes and I-880 and I-980

Create a dual left turn from southbound Broadway at the intersection of Broadway and 5th Streets

Provide improved signage to direct traffic from I-880/I-980 to Downtown Oakland, Jack London Square, Chinatown, and the city of Alameda

Construct a new southbound off-ramp for I-880 to Martin Luther King Jr. Way



FEHR & PEERS
TRANSPORTATION CONSULTANTS

July 2003
1027-0035\graphics\0035A-50 fig 8

Alameda Point

PROPOSED BROADWAY / JACKSON IMPROVEMENTS

FIGURE 8



their *Projections 2000* series. The ABAG projections are developed in consultation with the staff from the local jurisdictions and are intended to account for foreseeable future development projects.

A review of the ABAG employment projections for City of Alameda for the year 2020 revealed high levels of job growth as compared to the City's estimates. Therefore, manual adjustments to the ABAG land use forecasts were conducted based on consultation with the Project Team and City of Alameda staff. ABAG's 2020 employment projections for Alameda, excluding Alameda Point and Bay Farm Island, is 14,614 and the modifications to ABAG 2020 projections resulted in an employment projection of 8,341. This is approximately a 43 percent reduction from ABAG's projections for these areas. A more detailed comparison of the employment projections by area is presented in Table 4.

Table 4		
Comparison of Employment Projections		
	ABAG 2020	Revised 2020
Alameda Point	16,500	9,600
Bay Farm Island	4,231	4,231
Remainder	14,614	8,341
TOTAL	35,345	22,172

Figure 9 shows the locations where 2020 employment projections were modified. One of the key adjustments made to the 2020 land use assumptions occurred in zones that fell within the Park and Webster Streets commercial corridors. A 0.5 percent growth rate per year in jobs was applied in non-residential zones in those corridors, resulting in a total increase of 12.5 percent per zone by the year 2020.

ABAG is currently updating landuse and early indications are that the new landuse 2020 projections will be consistent with this analysis.

The Alameda Point development was converted to employment using different conversion factors for different building types (office, research and development, warehousing, etc.). Overall, Alameda Point will generate 9,600 jobs at full buildout.

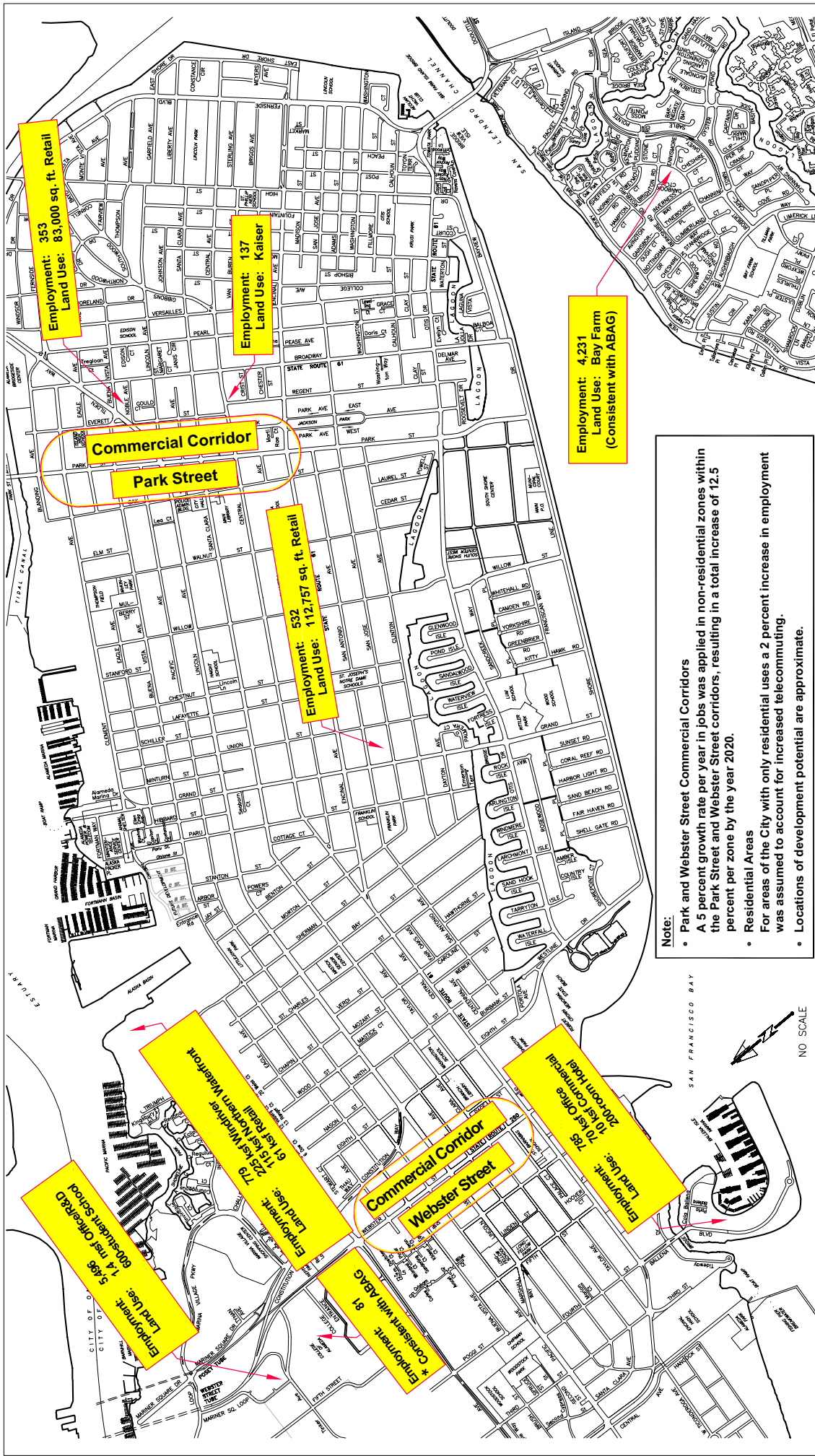

Note:

- Park and Webster Street Commercial Corridors
- A 5 percent growth rate per year in jobs was applied in non-residential zones within the Park Street and Webster Street corridors, resulting in a total increase of 12.5 percent per zone by the year 2020.
- Residential Areas
- For areas of the City with only residential uses a 2 percent increase in employment was assumed to account for increased telecommuting.
- Locations of development potential are approximate.

C. Project Traffic Estimates

The amount and effects of new traffic associated with the proposed redevelopment of Alameda Point was estimated using a three-step process: (1) trip generation; (2) trip distribution, and (3) trip assignment. In the first step, the amount of new traffic generated by the project, entering and exiting the project site, is estimated on a daily and peak-hour basis. In the second step, the general directions that new traffic would approach and depart the site are estimated. In the third step, project trips are assigned to specific streets and routes along the roadway network to reach their intended destination. The results of this three-step process are described in the following sections.

1. Trip Generation

The amount of traffic that would be generated by the proposed Project was estimated based on the data presented in the Institute of Transportation Engineers' (ITE) *Trip Generation* (6th Edition, 1997) for the following land uses:

- General Office Building
- Residential
- Warehousing
- Manufacturing
- Research and Development Center

The AM and PM peak hour trips rates for the specialty retail component of the proposed Project are based on San Diego Association of Government's (SANDAG) traffic data and trip rates.

The total trip generation for Alameda Point is presented in Table 5. As shown, the Project would generate 4,788 trips (3,279 inbound and 1,509 outbound) in the AM peak hour and 5,960 trips (2,331 inbound and 3,628 outbound) in the PM peak hour. The employment component of the Project would generate the majority of the traffic with approximately 65 percent of the total trips in the AM peak hour and 52 percent in the PM peak hour.

Table 5 Project Trip Generation							
Land Use	Size (dwelling units, ksf)	Total Trip Generation					
		AM Peak Hour			PM Peak Hour		
		Total	In	Out	Total	In	Out
Residential ^a	1,634	1,144	274	870	1,522	980	543
Employment ^b	3,311	3,101	2,625	476	3,081	673	2,407
Specialty Retail	388	543	380	163	1,357	678	678
TOTAL		4,788	3,279	1,509	5,960	2,331	3,628

Notes: ^a Residential development includes Multi-Unit Replacement housing, Affordable Duplexes, and Single-Family Detached housing.
^b Employment category includes Office, Warehousing, Manufacturing, and Research & Development uses.
Source: Institute of Transportation Engineers, SANDAG, and Fehr & Peers, June 2003.

Given that Alameda Point would have the site characteristics of a multi-use development, this study anticipates that internal trip-making between the residential, employment, and retail uses would occur. A key characteristic of a multi-use development is that trips among the various land uses can be made on site and these internal trips are not made on the external street system, but on internal pathways or roadways. A high proportion of these internal trips would be made by either walking or bicycling.

To account for this internalization, this study utilized internal capture rates contained in the Institute of Transportation Engineers' (ITE) *Trip Generation* (6th Edition, 1997) manual in conjunction with landuse-specific factors from the *Portland Trip Generation & Mode Split* manual (Exhibit A provides a compilation of internal capture rates estimated at various multi-use developments in the United States). The peak hour internal capture rates by land use presented in Table 6 can generally be defined as percent reductions that can be applied to the trip generation estimates for individual land uses to account for trips internal to the site. A high proportion of these internal trips would be made by either walking or bicycling.

Table 6 Internal Capture Rates						
Destination	Origin					
	AM Peak Hour			PM Peak Hour		
	Residential	Employment	Retail	Residential	Employment	Retail
Residential	0.00	0.02	0.12	0.00	0.02	0.12
Employment	0.00	0.01	0.03	0.00	0.01	0.03
Retail	0.53	0.23	0.20	0.53	0.23	0.20

Source: *Portland's Trip Generation & Mode Split* for Transit Oriented Developments.

In addition to the internalization that is expected to occur within the Project site, this analysis also assumes a reduction for Transportation Demand Management (TDM) measures. TDM is a set of strategies, measures and incentives to encourage people to walk, bicycle, use public transportation, carpool or use other alternatives to driving alone. TDM measures produce more mobility on the existing transportation systems, boost economic efficiency of the current transportation infrastructure, improve air quality, save energy, and reduce traffic congestion. This study applied a 30 percent reduction for office uses and 10 percent reduction for residential uses as described in the *TDM Plan*. No TDM reduction was applied to the retail uses.

Based on the internal capture rates presented in Table 6 and the TDM reductions described above, the resulting net new trips external to Alameda Point is displayed in Table 7. As shown, the net reduction in trips, resulting from transportation demand measures and internalization of trips at Alameda Point, is 1,797 trips in the AM peak hour and 2,657 trips in the PM peak hour. Furthermore, these reductions present a 38 percent decrease of the total external trips to the site in the AM peak hour and a 45 percent decrease in the PM peak hour.

Table 7 Net New External Trips							
Land Use	Size (dwelling units, ksf)	AM Peak Hour			PM Peak Hour		
		Total	In	Out	Total	In	Out
Residential ^a	1,634	885	212	673	1,178	758	420
Employment ^b	3,311	2,084	1,764	320	2,070	453	1,618
Specialty Retail	388	22	15	7	54	27	27
NET NEW TRIPS		2,991	1,991	1,000	3,303	1,238	2,065
TOTAL PROJECT TRIPS		4,788	3,279	1,509	5,960	2,331	3,628
Net Reduction in Trips		-1,797	-1,288	-509	-2,657	-1,093	-1,563
Notes: ^a Residential development includes Multi-Unit Replacement housing, Affordable Duplexes, and Single-Family Detached housing. ^b Employment category includes Office, Warehousing, Manufacturing, and Research & Development uses.							
Source: Institute of Transportation Engineers and Fehr & Peers, June 2003.							

2. Trip Distribution and Assignment

The trip distribution pattern for the proposed development was estimated based on the trip distribution process used in the Alameda County Congestion Management Agency's Alameda countywide model, which estimates the direction of travel for each trip that is produced and attracted by the trip generation estimates. Figures 8 through 10 present the AM and PM peak hour trip distributions by land use for trips entering and exiting Alameda Point from three directions: (1) East Alameda, (2) South-Central Alameda, and (3) Oakland.

As shown on Figure 10, the majority of retail traffic into the project site is expected to come from the east with 62 percent during the AM peak hour and 58 percent during the PM peak hour. Another 25 percent of the AM peak hour and 26 percent of the PM peak hour traffic is expected to come from Oakland via the Webster tunnel. The remaining 13 percent of AM peak hour and 16 percent of PM peak hour traffic will come from the south-central Alameda. Similar calculations were done to obtain the trip distribution patterns for retail traffic exiting the project site. Due to the retail's high capture rate from the island, very few trips are expected to utilize the Webster and Posey tubes.

Figures 11 and 12 present the estimated trip distributions for the office and residential components of the Project. Approximately one-half of residential and one-half of employment trips are expected to travel through the tubes during the peak hours.

Using the trip distribution patterns shown on Figures 10 through 12 and the trip generation estimates shown in Tables 4 and 6, the project traffic was assigned to the roadway network. Figure 13 shows the peak hour project trips assigned to each study intersection external to Alameda Point.

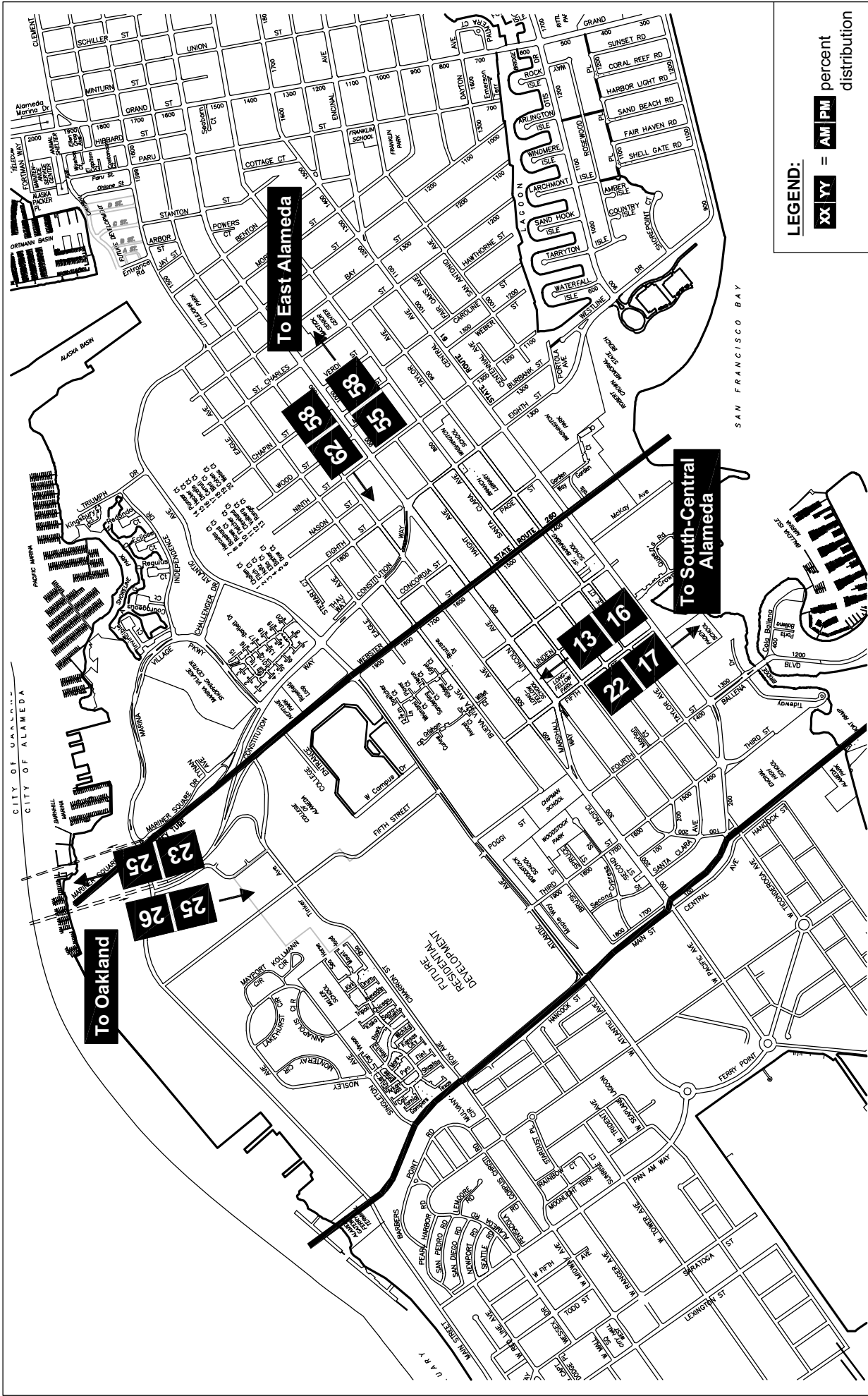

Alameda Point
**TRIP DISTRIBUTION
 RETAIL**
FIGURE 10

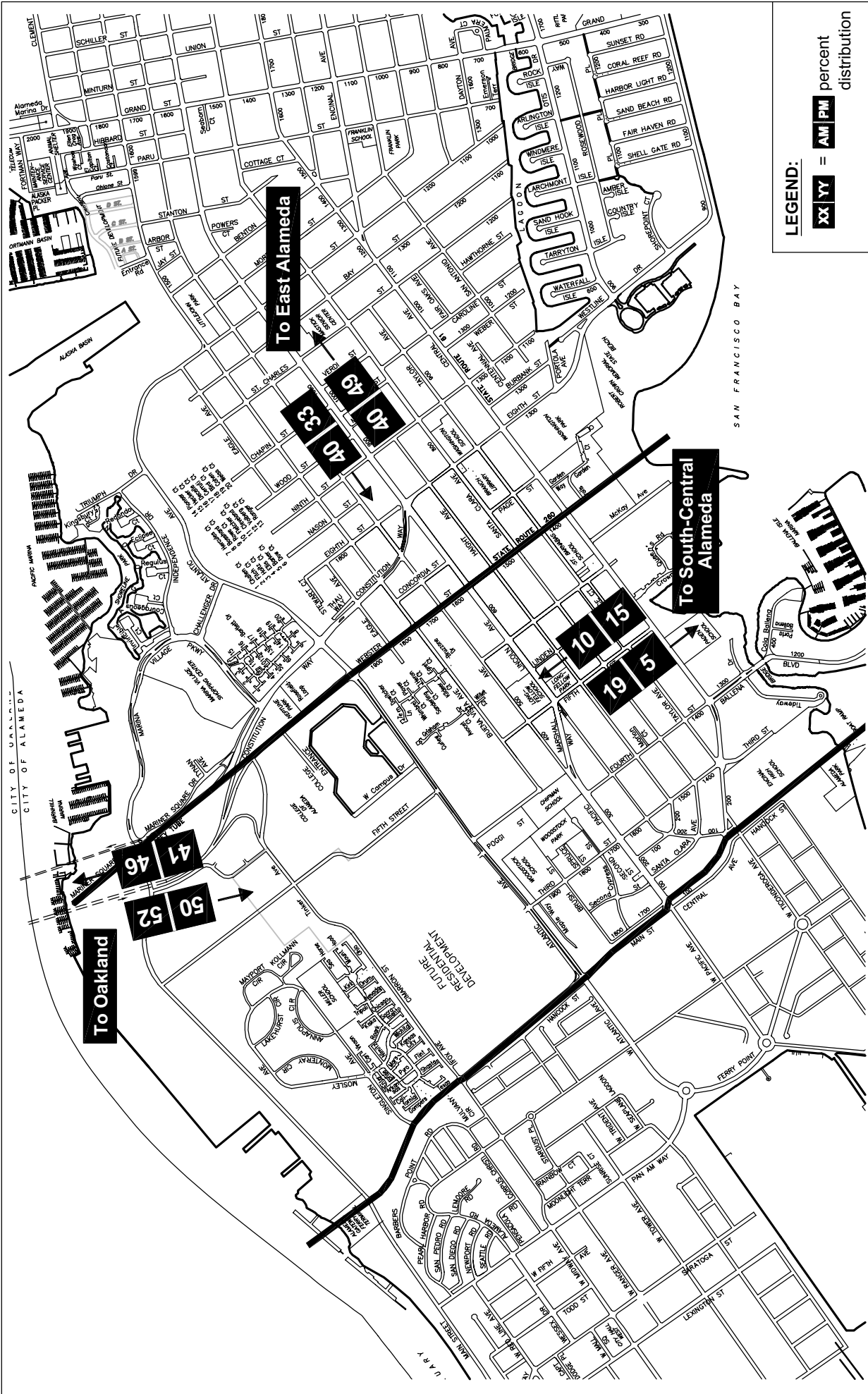

Alameda Point
**TRIP DISTRIBUTION
 EMPLOYMENT**
FIGURE 11

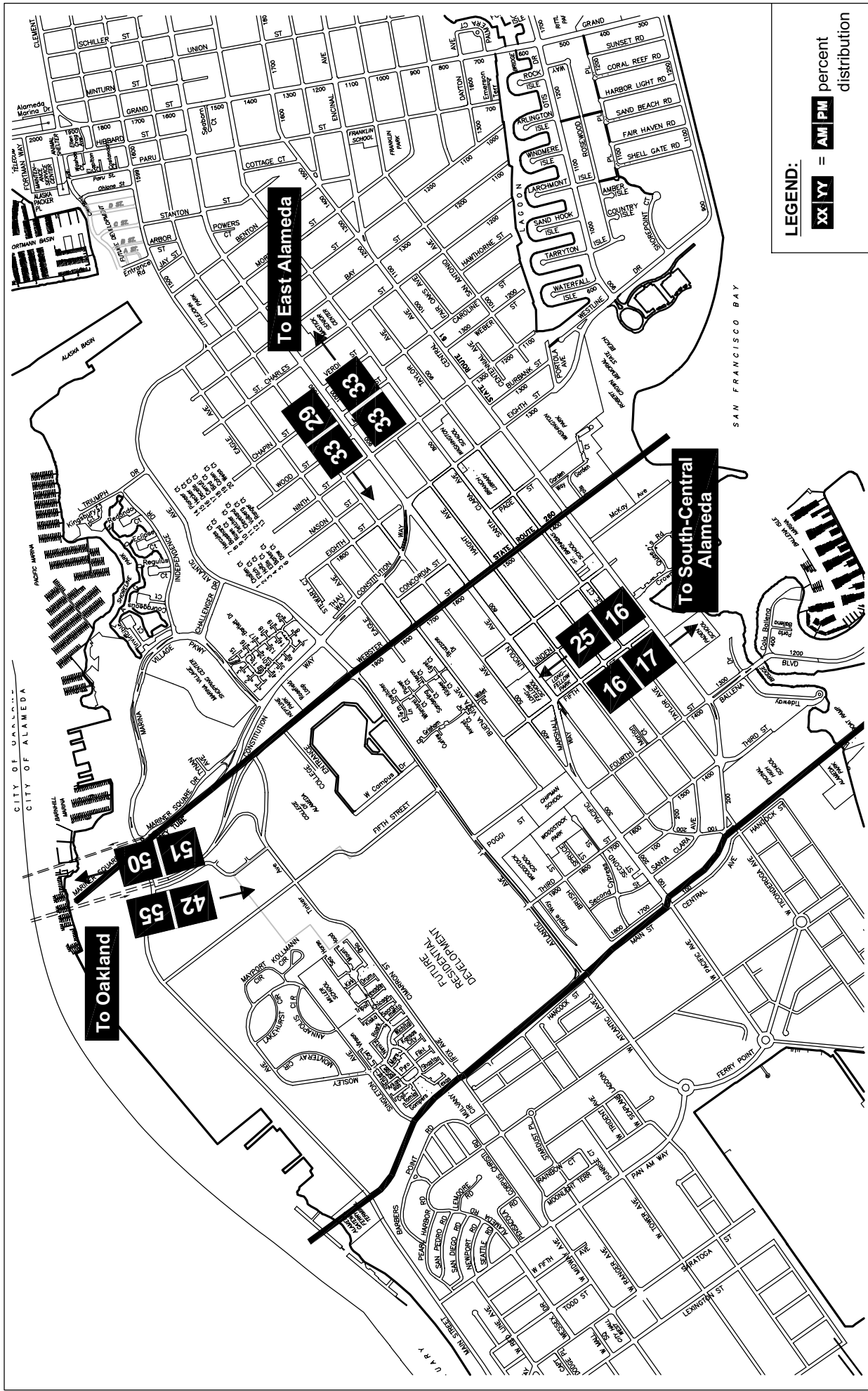

Alameda Point
**TRIP DISTRIBUTION
 RESIDENTIAL**
FIGURE 12

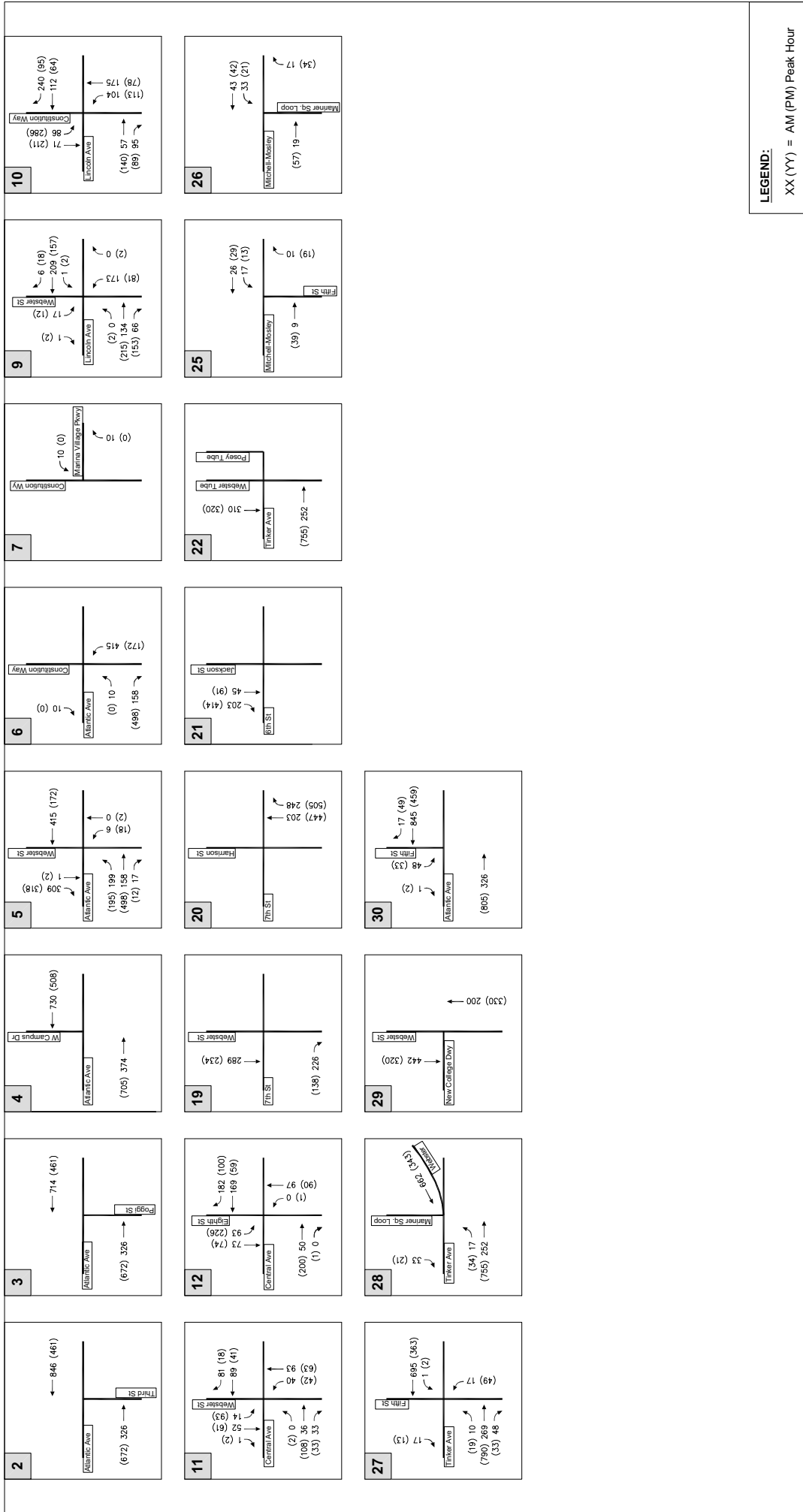

3. Cumulative (Year 2020) Plus Project Traffic Volumes

Future traffic volumes were derived by estimating the traffic growth between the 2020 traffic projections to Year 2000 traffic projections from the Alameda County Congestion Management Agency's Alameda countywide model. The estimated growth in traffic was then added to existing traffic counts to develop the cumulative baseline traffic volumes. The Project traffic, shown in Figure 12, was then added onto the cumulative baseline traffic volumes to develop the cumulative plus Project forecasts. Traffic volumes for the study intersections internal to Alameda Point were further adjusted to account for internalization that is expected within the Project site. Figure 14 illustrates the resulting AM and PM peak-hour traffic volumes for cumulative (Year 2020) plus Project conditions.

D. Intersection Levels of Service

Tables 8-A compares the AM and PM peak hour levels of service for each of the 21 existing study intersection to the resulting levels of service under Cumulative Plus Project conditions. Table 8-B presents the resulting levels of service for the 10 proposed study intersections mentioned earlier in this chapter.

As shown in Table 7-A, the study intersections are expected to maintain current operations at LOS D or better under both peak hours with the exception of 3 intersections in Alameda and one intersection in Oakland.

In the AM peak hour, the intersection that is expected to deteriorate from a current acceptable level of service (LOS C) to an unacceptable LOS E is Central Avenue / Eighth Street.

In the PM peak hour, the intersection that is expected to deteriorate from a current acceptable level of service (LOS D) to an unacceptable LOS E is Atlantic Avenue / Webster Street.

The intersections that are expected to deteriorate to LOS E or F under both the AM and PM peak hours are:

- Atlantic Street / Constitution Way
- Jackson Street / 6th Street

As currently occurs, the Jackson Street / 6th Street intersection would continue to experience vehicle queues such that they spillback to the Jackson Street / 7th Street and Harrison Street / 7th Street intersections. This is largely due to the addition of project traffic in the tubes, particularly for the movement exiting the Posey tube to the I-880 on-ramp at the Jackson Street / 6th Street intersection.

In addition, this study assumed that improvements to the Main Street / Tinker Avenue / Midway Avenue intersection would be included as part of the Tinker Avenue Extension project. Therefore, based on the projected traffic volumes at this intersection, this traffic analysis assumed the installation of a traffic signal as well as the following roadway improvements:

- Provide one additional through lane on eastbound Midway Avenue;
- Provide one exclusive left-turn lane on northbound and southbound Main Street; and
- Provide an exclusive left-turn lane for westbound Tinker Avenue.

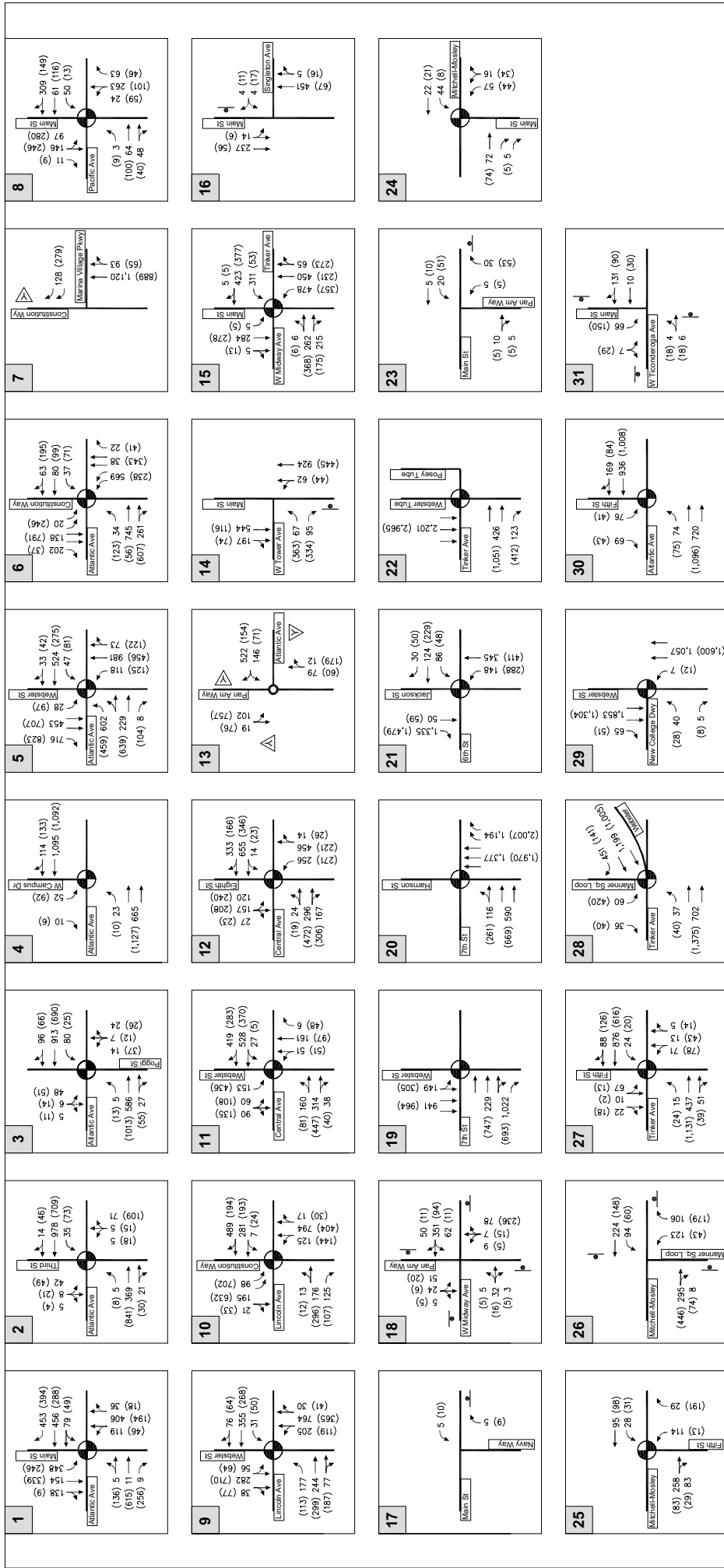

LEGEND:
 XX (YY) = AM (PM) Peak Hour Traffic Volumes
 = Traffic Signal
 = Sloped Sign
 = Yield
 = Roundabout

Alameda Point
CUMULATIVE PLUS PROJECT CONDITIONS
PEAK HOUR VOLUMES
FIGURE 14

Table 8 - A
Intersection Levels of Service
Cumulative (Year 2020) Plus Project Conditions

No.	Intersection	Traffic Control	Existing (Delay: Sec. / Veh.)		Cumulative Plus Project (Delay: Sec. / Veh.)	
			AM Peak Hour	PM Peak Hour	AM Peak Hour	PM Peak Hour
1	Atlantic Avenue / Main Street	Traffic Signal ¹	B (12.2)	C (20.9)	C (34.6)	D (39.2)
2	Atlantic Avenue / Third Street	Traffic Signal	A (7.4)	B (11.3)	A (6.8)	A (9.1)
3	Atlantic Avenue / Poggi Street	Traffic Signal	A (6.2)	A (7.3)	A (6.5)	A (6.7)
4	Atlantic Avenue / West Campus Drive	Traffic Signal	A (9.4)	A (9.4)	C (21.9)	C (25.5)
5	Atlantic Avenue / Webster Street	Traffic Signal	D (35.1)	D (44.5)	D (48.0)	E (76.1)
6	Atlantic Avenue / Constitution Way	Traffic Signal	D (37.7)	D (41.5)	F (236.0)	F (88.0)
7	Constitution Way / Marina Village Parkway	Side-Street Stop-Controlled	B (14.5)	B (15.0)	B (14.6)	C (16.4)
8	Main Street / Pacific Avenue	Traffic Signal	A (7.4)	B (10.3)	A (9.8)	D (40.0)
9	Webster Street / Lincoln Avenue	Traffic Signal	A (8.6)	A (8.2)	B (10.0)	A (9.1)
10	Constitution Way / Lincoln Avenue	Traffic Signal	C (28.5)	C (26.2)	D (48.3)	D (41.4)
11	Webster Street / Central Avenue	Traffic Signal	B (15.7)	B (14.5)	B (19.9)	B (15.6)
12	Central Avenue / Eighth Street	Traffic Signal	C (26.5)	C (31.3)	E (79.1)	D (39.3)
13	Pan Am Way / Atlantic Avenue	Roundabout ²	A (7.4)	A (6.8)	A (8.7)	A (9.6)
14	Main Street / West Tower Avenue	AWSC ³	A (9.7)	B (10.6)	C (24.0)	C (18.4)
15	Main Street / West Midway Avenue / Tinker Avenue	Signalized ⁴	C (16.5)	B (14.1)	D (37.7)	C (24.4)
16	Main Street / Singleton Avenue	Side-Street Stop-Controlled	B (10.9)	A (9.5)	B (11.5)	A (9.9)
17	Main Street / Navy Way	Side-Street Stop-Controlled	A (0.0)	A (0.0)	A (0.0)	A (0.0)
18	Pan Am Way / West Midway Avenue	AWSC	A (7.7)	A (7.0)	B (11.3)	A (8.0)
19	Webster Street / 7 th Street	Traffic Signal	A (8.6)	A (9.9)	B (10.3)	A (9.7)
20	Harrison Street / 7 th Street	Traffic Signal	A (8.0)	A (8.8)	A (8.0)	C (30.6) ⁵
21	Jackson Street / 6 th Street	Traffic Signal	D (36.8)	C (30.6)	F (92.5)	F (120.3)

Notes:

¹ Signalized intersection LOS based on average intersection delay, based on the methodology in the *Highway Capacity Manual*, 2000 Edition.

² The SIDRA software was used to analyze the proposed single-lane roundabout. The methodologies used in this software are consistent with the methodologies contained in the *Highway Capacity Manual*, 2000 Edition. The LOS reported indicates the approach with the highest delay.

³ All-way stop-controlled (AWSC) intersection LOS based on average intersection delay, based on the methodology in the *Highway Capacity Manual*, 2000 Edition.

Side Street stop controlled

⁴ Under Cumulative conditions, this analysis assumes a traffic signal will be installed as part of the Tinker Avenue Extension.

⁵ Although the resulting LOS indicates acceptable traffic operations, vehicle queues occur on the northbound approach and extend into the Posey tunnel. This is largely due to the heavy traffic movement from the island to the I-880 on-ramp at the Jackson Street / 6th Street intersection.

Source: Fehr & Peers, June 2003.

Maintaining current lane configurations and traffic control at the Main Street / Tinker Avenue / Midway Avenue intersection under Cumulative Plus Project conditions would result in unacceptable traffic operations under both peak hours.

Table 7-B indicates that under Cumulative Plus Project conditions, all new intersections are expected to operate acceptably at LOS C or better during both peak hours.

Table 8 - B Intersection Levels of Service Cumulative (Year 2020) Plus Project Conditions				
No.	Intersection	Traffic Control	LOS / Delay (Sec. / Veh.)	
			AM Peak Hour	PM Peak Hour
22	Webster Street / Tinker Avenue	Signalized ¹	A (7.2)	C (29.7)
23	Main Street / Pan Am Way	Side street stop	A (7.4)	A (7.4)
24	Main Street / Mitchell-Mosley	Signalized	B (12.2)	B (11.0)
25	Fifth Street / Mitchell-Mosley	AWSC ²	A (8.5)	B (10.6)
26	Mitchell-Mosley / Marina Square Loop	Signalized	B (11.1)	C (16.1)
27	Tinker Avenue / Fifth Street	Signalized	A (10.0)	A (8.8)
28	Tinker Avenue / Marina Square Loop	Signalized	A (5.4)	B (18.6)
29	Webster Street / New College Driveway	Signalized	A (3.6)	A (2.8)
30	Atlantic Avenue / Fifth Street	Signalized	A (5.8)	A (4.4)
31	Main Street / West Ticonderoga Avenue	AWSC	A (7.7)	A (8.1)
Notes: ¹ Signalized intersection LOS based on average intersection delay, based on the methodology in the <i>Highway Capacity Manual</i> , 2000 Edition. ² All-way stop-controlled (AWSC) intersection LOS based on average intersection delay, based on the methodology in the <i>Highway Capacity Manual</i> , 2000 Edition. Side Street stop controlled Source: Fehr & Peers, June 2003.				

IV. CONCLUSIONS AND RECOMMENDATIONS

This chapter summarizes the key issues raised by the travel demand forecast and key recommendations for site access and on-site circulation. Key findings of the travel demand forecast were that just four of the 32 study intersections would fail during either the AM or PM peak hour while the vast majority of study intersections would operate acceptably (LOS D or better), with employment-related trips to Alameda Point impacting each of the four failing intersections. Three of the four failing intersections are heavily impacted by trips through the Webster and Posey Tubes.

A. Off-Site Impacts

The following off-site intersections are forecasted to operate at unacceptable levels of service (LOS) during 2020 cumulative conditions:

- *Atlantic Avenue* intersections with *Webster Street* and *Constitution Way*. Atlantic Avenue serves as the main east-west connector between Alameda Point and the Webster / Posey Tubes. Development of the proposed Tinker Avenue extension will provide an alternate route for traffic between the tubes and Alameda Point, and the majority of employment-related trips originating outside of the island will be expected to utilize Tinker Avenue.
- *Jackson Street / 6th Street* intersection in Oakland, which provides access from the Posey Tube to northbound Interstate 880. This intersection would operate unfavorably without redevelopment of Alameda Point. Project trips would be expected to comprise 12% of trips through this intersection during the AM peak hour and 20% of trips during the PM peak hour under cumulative conditions.
- *Central Avenue / Eighth Street* intersection in Alameda, primarily due to an expected increase in employment-related trips bound for Alameda Point from eastern Alameda.
- *Webster and Posey Tubes*: With regard to the current and projected traffic traveling through the Webster and Posey Tubes as shown in Tables 9 and 10, key findings of the travel demand forecasting indicate that:
 - The Project would generate 1,423 trips through the tubes during the AM peak hour (972 southbound; 451 northbound) and 1,615 trips through the tubes during the PM peak hour (663 southbound; 952 northbound) ;
 - Project trips (trips traveling to or from Alameda Point) would constitute 22% of the total traffic in the tubes during the AM and PM peak hours;
 - The capacity of the northbound Posey Tube would be exceeded during the PM peak hour, due to background traffic growth and Project trips, and the southbound Webster Tube would approach capacity during the AM peak hour, highlighting the need for transit options and TDM measures targeted at employment-related trips originating outside of the island of Alameda. Alternatively, the provision of additional housing units at Alameda Point could reduce the need for employees to reside outside of Alameda; and

- Traffic leaving Alameda in the AM peak hour and entering Alameda during the PM peak hour would not exceed the capacity of the tubes.

Table 9 Vehicle Trips in Webster and Posey Tubes						
Direction	Period	Capacity	Existing Traffic Volume ¹	Existing Percent Capacity (V/C)	2020 Traffic Volume ²	2020 Percent Capacity (V/C)
Southbound (Webster Tube)	AM Peak Hour	4,000	2,249	56%	3,727	93%
Northbound (Posey Tube)	AM Peak Hour	4,000	2,383	60%	2,571	64%
Southbound (Webster Tube)	PM Peak Hour	4,000	3,088	77%	3,320	83%
Northbound (Posey Tube)	PM Peak Hour	4,000	2,689	67%	4,007	100%

Source: Fehr & Peers Associates, 2003.

Table 10 Percentage of Tube Traffic Volume to / from Alameda Point Redevelopment				
Direction	Period	Alameda Point Project Trips in Tube(s)	Total 2020 Traffic Volume in Tube(s)	Percent of Tube Trips generated by Alameda Point
Southbound (Webster Tube)	AM Peak Hour	972	3,727	26%
Northbound (Posey Tube)	AM Peak Hour	451	2,571	18%
AM Total	AM Peak Hour	1,423	6,298	23%
Southbound (Webster Tube)	PM Peak Hour	663	3,320	20%
Northbound (Posey Tube)	PM Peak Hour	952	4,007	24%
PM Total	PM Peak Hour	1,615	7,327	22%

Source: Fehr & Peers Associates, 2003.

1 Existing southbound volumes based on General Plan EIR. Existing northbound volumes based on traffic counts provided by the City of Alameda, July 2003.

2 2020 traffic volumes include project trips and cumulative background traffic growth, derived from the City of Alameda traffic model and incorporating revised population and employment data.

Key recommendations (Off-Site Impacts)

- Prioritize transit options and transportation demand management (TDM) measures that reduce vehicle trips generated by employment trips bound for Alameda Point from outside the island of Alameda, in order to reduce inbound AM peak hour trips and PM outbound peak hour trips that would travel through the tubes and potentially impact intersections in downtown Oakland and along Atlantic Avenue
- Continue studying the feasibility of the proposed gondola as a means of improving regional access, particularly for employment trips, and study additional improvements to provide transportation connections between the proposed gondola station in Alameda Point and employment locations that are not within walking distance (generally one-fourth to one-half of a mile) of the proposed gondola station. Alternatively, pursue refinements to the development plan that would locate a greater amount of employment and housing within walking distance of the proposed gondola station (Measure A constraints may preclude this possibility).
- Implement bicycle projects and local transit improvements on the island of Alameda that would potentially reduce employment-related trips originating within the island of Alameda
- Converting the northbound through/right-turn lane to allow all movements (left-through-right) would potentially improve traffic operations to an acceptable level of service in the AM peak hour under Cumulative Plus Project conditions;
- Signal timing improvements at the Atlantic Avenue / Constitution Way intersection that includes converting the east-west direction signal phasing from a split phase to a protected left-turn phase would potentially improve traffic conditions to acceptable levels of service in both the AM and PM peak hours under Cumulative Plus Project conditions;

Given that the impact at the Jackson Street / 6th Street intersection over the next 20 years cannot be attributed to a single project or plan and is within the City of Oakland limits, the mitigations/recommendations will require the cooperation of the CMA and Caltrans as well as the City of Oakland. For this reason, the City of Alameda cannot act unilaterally to require that the anticipated problems be corrected through mitigation. However, the City of Alameda is committed to working with these agencies to identify appropriate solutions to mitigate the traffic impact and contribute a "fair share" to the improvement costs of a mutually acceptable solution.

B. Site Access

- The primary access point in and out of Alameda Point will be at *Atlantic Avenue / Main Street* intersection. Approximately 13,500 vehicles per day would enter and exit the site from this intersection, which will operate at LOS E in the AM peak period.
- *Tinker Avenue Extension* would provide an additional access point for approximately 7,000 daily vehicles.
- *Pacific Avenue* would provide access for approximately 4,000 daily vehicles.

- *Main Street*, at the eastern edge of Alameda Point, would serve approximately 6,000 daily vehicles within Alameda Point. Main Street currently has four travel lanes but no center turn lanes.

Key recommendations (Site Access)

- Provide left-turn pockets on Main Street, particularly to serve northbound traffic entering Alameda Point. Given the projected traffic volumes, this could potentially be accomplished by reducing the existing travel lanes from four to two.
- Provide two through lanes for eastbound traffic exiting West Midway Avenue on to Tinker Avenue at the intersection with Main Street, and provide dedicating left-turn lanes for all directions at this intersection

C. Internal Circulation

Existing and proposed internal roads within Alameda Point are each designated with two travel lanes; proposed “boulevards” would also include center medians and left-turn pockets. Key findings with regard to vehicle circulation within Alameda Point include:

- *West Midway Avenue* would serve approximately 13,000 vehicles daily, and is expected to serve as the primary entrance point for employment-related vehicle trips originating from the tubes.
- *Atlantic Avenue* would serve approximately 13,500 daily vehicles within Alameda Point. Atlantic Avenue is designated as a “boulevard” with two through lanes a center turn-lane/median.

Key recommendations (Internal Circulation)

- Designate West Midway Avenue as a “boulevard street” with two travel lanes with a center median and left-turn pockets provided at key locations (the Transportation Plan for Alameda Point currently designates West Midway Avenue as a “mixed use feeder” with two travel lanes but no center turn lanes)

D. Bicycle Access and Circulation

Development of the planned network of bicycle paths, on-street bicycle lanes and bicycle support facilities such as bicycle parking will potentially reduce on-site vehicle trips and trips originating elsewhere on the island of Alameda, including employment-related trips. The transportation plan for Alameda Point includes bicycle lanes on primary streets within Alameda Point and bicycle paths around the perimeter of the project area. Given the adjoining grid of streets elsewhere in Alameda, and the flat topography of the island, bicycling to and from Alameda Point will be a convenient and potentially attractive option for trips within beginning or ending within the City of Alameda.

Key Recommendations (Bicycle Access and Circulation)

Pursue implementation of the projects identified in the City of Alameda's Bicycle Master Plan that would link Alameda Point both internally and to other destinations throughout the City. Specific bicycle routes identified within Alameda Point or nearby include:

Proposed Bicycle Paths:

- Main Street between Singleton Avenue and Ferry Terminal.
- A circumferential path along the waterfront around the entire project site, using roadway alignments such as Main Street and Ferry Point and abutting the Estuary and San Francisco Bay (noting that the final alignment will require coordination with other agencies).
- Monarch Street from the Estuary to San Francisco Bay.
- Atlantic Avenue between Webster Street and Main Street.
- Lexington immediately south of Main Street.

Proposed Bicycle Lanes:

- Lexington Street between West Red Line Avenue and Atlantic Avenue (extended).
- Saratoga Street between West Red Line Avenue and Atlantic Avenue (extended).
- Midway between Main Street and Monarch Street.
- Pan Am Way/ Ferry Point between Main Street and Atlantic Avenue.
- Oriskany Avenue between Ferry Point and Third Street.
- Atlantic Avenue between Ferry Point and Main Street.
- Tinker Avenue west of Webster Street.
- Third and Fifth Streets between Central and Mosley Avenues.
- Central Avenue.
- From Main Street/Midway Street to Webster Street along Oakland Estuary (extended).
- From Main Street to Webster Street along Midway alignment (extended).
- East Campus Drive and Mariner's Square Loop from Atlantic Avenue to Marina Village Parkway.

E. Pedestrian Access and Circulation

Pedestrian circulation is a key component of the transportation plan for Alameda Point and the proposed street system includes streetscape improvements, a continuous sidewalk system and maintenance of the grid street system for most portions of Alameda Point. A refinement to the transportation plan that could further improve pedestrian circulation could include:

- More fully extend the existing street grid to create smaller blocks and shorter walking distances for pedestrians, particularly within areas planned for retail or employment-related uses.